

# **GB5 TEMPERATURE CONTROLLER**

## **INSTRUCTION MANUAL**

**Digitry Company, Inc.**

188 State Street, Suite 21  
Portland, ME 04101

©1991–2005 by Digitry Company, Inc.  
All Rights Reserved

January 2005



Dear Customer,

Welcome to the growing family of Digitry Controller users. Digitry is proud of its record of delivering "user friendly" Programmable Temperature Controllers for ovens, kilns, lehrs and furnaces since 1980. The GB5 is in use for controlling processes associated with heating ceramics and glass in both factories and studios around the world. These processes include annealing, fusing, slumping, fire polishing, kiln casting, pâte de verre, crystalline glazing, bisque firing, and batch melting.

In the following pages, you will find complete information on the use and installation of your GB5. As you will quickly learn, ease of operation and programming flexibility are the trademarks of your Digitry Programmable Temperature Controller.

We appreciate hearing from owners of the GB5. Please contact us with any questions, suggestions, or application stories you would like to discuss. Our telephone number and email address are listed in Chapter 6 of this manual under "Sales and Service."

Many of the features and design elements of Digitry's controllers were suggested to us by our users. This is one of the reasons Digitry controllers continue to be the easiest to use and most intuitive temperature controllers available today.

Congratulations on your decision to increase efficiency and productivity in your workplace with Digitry's GB5 Programmable Temperature Controller.

Sincerely,

Richard L. Tenney  
President



# Contents

<b>1</b>	<b>Introduction</b>	<b>1</b>
<b>2</b>	<b>Overview of the GB5</b>	<b>3</b>
2.1	Capabilities . . . . .	3
2.2	Modes . . . . .	6
2.3	Status Indicator Lights . . . . .	6
2.4	Numerical Displays . . . . .	7
2.5	Keyboard . . . . .	8
<b>3</b>	<b>Programming</b>	<b>15</b>
3.1	Introduction . . . . .	15
3.2	Entering a Program . . . . .	17
3.3	Reviewing a Program . . . . .	18
3.4	Copying and Exchanging Programs . . . . .	19
3.5	Looping . . . . .	20
3.6	Delayed Start . . . . .	21
3.7	Sample Program . . . . .	22
<b>4</b>	<b>Special Features of the GB5</b>	<b>27</b>
4.1	Automatic Hold . . . . .	27
4.2	Guaranteed Temperatures . . . . .	28
4.3	Error Messages . . . . .	28
4.4	Disabling Error Messages . . . . .	30
4.5	Behavior During Power Failures . . . . .	30
4.6	“COld” Readings . . . . .	31
4.7	Memory Failure . . . . .	32
<b>5</b>	<b>Installation</b>	<b>33</b>
5.1	Overview . . . . .	33
5.2	Thermocouples . . . . .	34

5.3	Sending Units . . . . .	35
5.4	Connecting Outputs . . . . .	39
5.4.1	Mechanical or Mercury Contactor . . . . .	40
5.4.2	Solid-State Power Relay . . . . .	42
5.4.3	4–20 Milliamp Current Loop . . . . .	46
5.5	Powering Your GB5 . . . . .	48
5.6	Internal Protection . . . . .	48
5.7	DOs and DON'Ts . . . . .	49
5.8	Additional Help . . . . .	50
<b>6</b>	<b>Reference</b>	<b>51</b>
6.1	GB5 Specifications . . . . .	51
6.2	Accuracy . . . . .	52
6.3	Sales and Service . . . . .	52
6.4	Loaner Program . . . . .	53
6.5	Warranty Information . . . . .	53
<b>7</b>	<b>Glossary</b>	<b>55</b>
<b>8</b>	<b>Troubleshooting</b>	<b>61</b>
	<b>Programming Forms</b>	<b>63</b>

# List of Figures

- 2.1 GB5 Face . . . . . 5
- 2.2 Keyboard Functions . . . . . 9
  
- 3.1 Simple Profile . . . . . 16
- 3.2 Filled In Programming Form . . . . . 23
- 3.3 Sample Profile Graph . . . . . 24
- 3.4 Sample Profile . . . . . 25
  
- 5.1 GB5 back . . . . . 34
- 5.2 Sending Units . . . . . 36
- 5.3 Type K Thermocouple Connections . . . . . 37
- 5.4 Contactor Connections . . . . . 41
- 5.5 Typical Mercury Contactor Connections . . . . . 43
- 5.6 Solid-State Power Relay Connection . . . . . 44
- 5.7 Recommended Solid-State Relay Installation . . . . . 45
- 5.8 Modutrol Series M72XX Connection . . . . . 47





# Chapter 1

## Introduction

This manual introduces you to your GB5 Programmable Temperature Controller. It details how to operate and install it. You do not need prior experience with temperature controllers or computers. Just read and follow the simple instructions for programming and installing your GB5.

From time-to-time, we will refer to each of the units your are controlling with the GB5 as an “oven”, regardless of whether it is a lehr, annealer, furnace, or what-have-you.

This manual is divided into seven chapters. It is best to read Chapters 1 through 5 in succession. Chapter 6, the Glossary in chapter 7, and the troubleshooting guide in chapter 8 are handy reference sections to be used whenever needed.

Chapter 1 is this brief introduction.

Chapter 2 introduces you to the features and benefits of your GB5. The function of each operating mode, indicator light, LED display and keyboard button on the face of the GB5 is explained.

Chapter 3 teaches you how to program your GB5. The GB5 is easy to program once you are familiar with the layout of its controls, explained in Chapter 2. The chapter contains a sample profile that you may want to enter to become comfortable programming the unit. There are some pre-printed forms at the end of the manual to facilitate your working with profiles.

Chapter 4 explains the special features of the GB5, including how it behaves when power failures occur.

Chapter 5 details the steps for installing your GB5. Pay particular attention to the first section on thermocouples and Sending Units.



# Chapter 2

## Overview of the GB5

### 2.1 Capabilities

The GB5 has many capabilities and features that make it ideal for complex processes involving automatic temperature control, including glass, ceramics, metalwork, casting, etc. Its great versatility gives it a wide range of applications, and its ease of programming and simplicity of operation make it a favorite of users at all levels of technical proficiency.

- Simultaneous independent control of up to five ovens.
- User-programmable profiles.
- Up to fifteen setpoints per profile.
- Automatic ramping between setpoints.
- Maximum time of over three weeks per step, allowing over eleven months per profile.
- Automatic hold when temperature lags profile.
- Skip-step and keyboard hold functions, allowing manual control when needed.
- Looping back to beginning of program.
- Delayed start of program.
- Full 16-button keypad, allowing direct entry of times and temperatures without scrolling.

- Separate, large, bright LED displays for temperature and time.
- Retention of all profiles during power failures.
- Intelligent recovery from power failures and brown-outs.

The GB5 can be enhanced with several optional features.

- Remote temperature readouts, both standard and large size, permitting monitoring ovens from various convenient sites.
- Power sharing, allowing multiple ovens to share limited power.
- Zone control, allowing synchronization of profiles for separate zones.
- PC connectivity.
  - Graphing (chart recorder) of actual and programmed temperatures.
  - Data logging, giving a permanent record.
  - Remote monitoring for viewing progress of a profile at the PC, even over the Internet or using dial-up networking, for appropriately configured systems.
  - Entering profiles on the PC by typing at the keyboard, with a graph of the result.
  - Archiving profiles on the PC; keep an almost unlimited library of profiles for various kinds of work.
  - Copying profiles from the GB5 to the PC, for inspection, editing, and long-term storage.
  - Loading profiles from PC to the GB5; enter new profiles or use profiles previously stored on the PC.
  - Control of GB5 from PC; clear errors, stop, and even start an oven from the PC, even over the Internet or using dial-up networking, for appropriately configured systems.
  - Phone notification of events, such as errors and advancing from one step to the next.

A diagram of the face of the GB5 is on the following page.

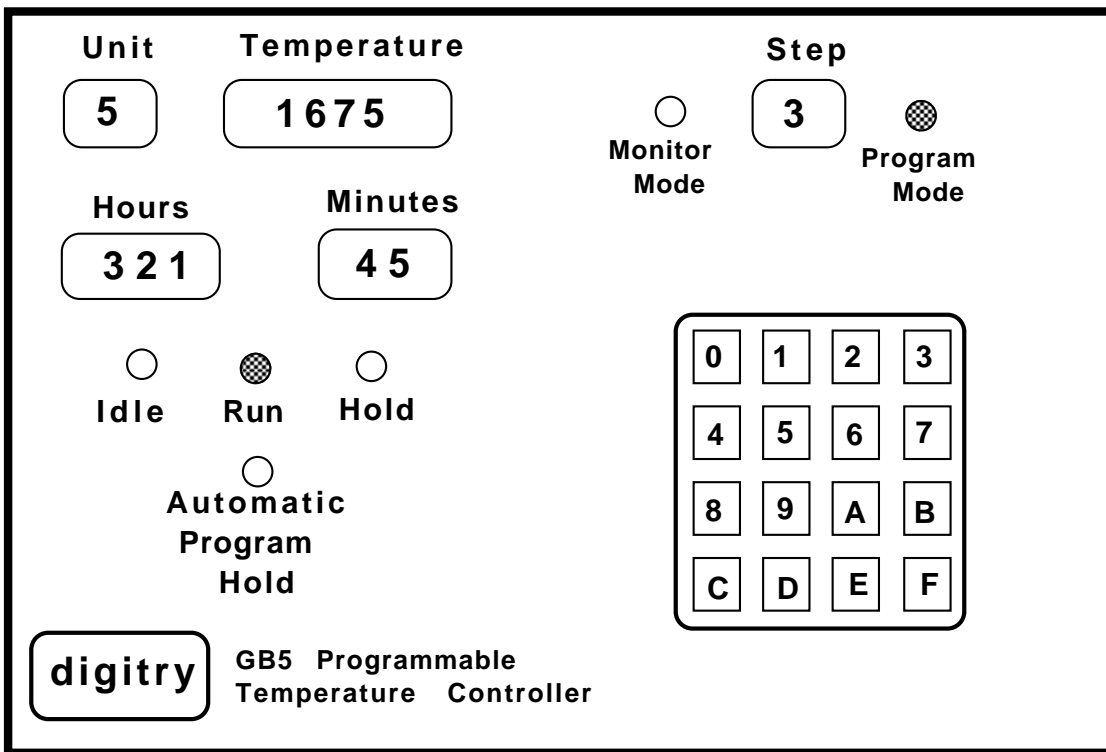

Figure 2.1: GB5 Face

## 2.2 Modes

There are two modes of operation for your GB5: MONITOR and PROGRAM. During standard operations, the GB5 usually is in the MONITOR MODE. When entering, changing or examining temperature profiles, the GB5 must be in PROGRAM MODE.

For those channels that support proportional output, the MONITOR mode has two display choices: remaining time and power level. Added to the PROGRAM mode, these two MONITOR displays may give the user the impression that there are three modes. If this includes you, don't worry.

## 2.3 Status Indicator Lights

There are two groups of indicator lights on the face of the GB5. The MODE lights are directly above the keyboard on either side of the STEP display. The four status indicator lights are to the left of the keyboard, directly beneath the TIME display.

**MONITOR MODE:** When the green MONITOR light is on, the GB5 is ready to display the temperature and either the time remaining or the power level of a given unit. Your units are constantly monitored by the GB5, even when the MONITOR light is not lit.

**PROGRAM MODE:** When the red PROGRAM light is on, the GB5 is ready to enter, examine, or change temperature profiles. Note that any programs that have already been started will continue to execute; working with one program has no effect on the others.

Button B on the keyboard is used to switch modes. See section 2.5, page 8, for details.

**IDLE:** The red IDLE light indicates that the control power to a selected unit is off and the unit timer is not running. Therefore, that unit is ready to begin STEP #1 of your program. Once the program has completed its cycle, the GB5 automatically returns the unit to IDLE. Resetting the unit using Button F (as described in section 2.5, page 8) also forces the GB5 into IDLE.

**RUN:** The green RUN light indicates that your unit has been activated. This means that the unit is following your program.

**HOLD:** The yellow HOLD light indicates that your program has reached an indefinite, programmed hold or that Button D has been pushed (also placing the unit in an indefinite hold). In either case, the unit timer stops running and the unit maintains the preset temperature.

**AUTO-HOLD:** The yellow AUTO-HOLD light indicates that the actual unit temperature is far below or above the calculated program temperature. This situation occurs when the programmed slope (calculated automatically according to the time and temperature set-points you entered into your program) is too steep to be achieved by your unit's capability to heat up or cool down. This light also comes during the last minute of any step until the programmed temperature is achieved. Whenever this light appears, the unit timer stops and remains stopped until the unit reaches the required temperature.

## 2.4 Numerical Displays

There are four numerical LED displays on the face of the GB5: one digit each for the UNIT and the STEP, four digits for the TEMPERATURE, and five digits for the TIME. Under most circumstances, each indicates information either about a profile being entered or about an oven being controlled. At other times, power level or error messages may appear in the TIME and TEMPERATURE displays. These are described in other sections of this manual.

**UNIT:** This display indicates the unit (*i.e.*, oven, kiln, lehr or furnace) that currently is being monitored or programmed.

**TEMPERATURE:** This display indicates temperature. In MONITOR MODE, this is the reading from your thermocouple; in PROGRAM MODE, it is the final temperature of a given step.

In MONITOR MODE, if no Sending Unit is attached to a Type K channel, this display will be 32° Fahrenheit (blank for Celsius). If the Sending Unit is attached to the GB5 but the thermocouple is not connected or is burnt out, the TEMPERATURE display will read extremely high, typically above 2350°F (1290°C), the alarm on the Sending Unit will sound ("buzz" or squeal) if it is a Type K Sending Unit. There is some more discussion of this topic in Section 5.3, page 36.

**TIME:** This display shows the time for the current step. The time indicated when the GB5 is in PROGRAM MODE denotes the length the step. When programming, the "HHH HH" will be displayed to indicate a programmed hold, *i.e.*, a soak of indefinite length, and "LLL LL" will be displayed to indicate a loop back to the beginning of the program.

Even more esoteric is the LL-LL and the LS-LS for copying and exchanging programs, which are described in Section 3.4, page 19.

In MONITOR MODE, the display shows the remaining time of the current step, and diminishes as the step proceeds. The timer is running whenever the green RUN light is on unless the HOLD or AUTO-HOLD light is on. The timer stops when your oven is IDLE. When the timer is stopped, the displayed time does not change. However, since a programmed hold has no time associated with it, the display shows “HHH HH”.

For proportional control channels of the GB5, the MONITOR MODE has two different displays, which differ only in what is shown in the bottom LEDs. The first display mode is the normal one described above. The second one replaces the time with a power level display. A 3-digit number representing the current power level (as a percent) is followed by the letters “PL” (for Power Level).

**STEP:** In MONITOR MODE, the number displayed directly above the keyboard indicates the current step of the program you are executing. In PROGRAM MODE, this LED display indicates the step you are entering or reviewing. The steps are indicated by the numbers “1” through “9”, and then “A” for the tenth step, “B” for the eleventh step, and so forth, up to “F” for the fifteenth step (the maximum number that can be programmed for any one unit). A horizontal bar “----” will appear in the TIME and TEMPERATURE displays if you try to enter more than 15 steps per unit or if you try to view a step after a Loop “LLL LL”.

## 2.5 Keyboard

The keyboard on the face of the GB5 consists of 16 buttons. There are 10 numerals, 0-9; and six special function buttons, A-F. The functions performed by the A-F buttons are printed above the keyboard. The chart in Figure 2.2 summarizes the functions performed in each operating mode.

**Button A—Unit:** Button A is used to select the unit that will appear in the display, i.e., the unit you will be monitoring or programming. Simply push Button A and then push the number of the unit (from 1-9) you wish to view. The unit number appears in the upper left hand corner of the GB5, below the word UNIT. Selecting a unit automatically invokes MONITOR MODE.

In addition to the five ovens that you can actually control, there are four units that are not connected to any temperature reading inputs or control outputs. These units, 6-9, are for storing programs that you may wish to use later. These “extra” programs may be either punched in directly, in the same way as with units 1-5, or exchanged or copied from other units, as will be explained shortly. Since units



Button	Function	In PROGRAM MODE	In MONITOR MODE
<b>A</b>	<b>Unit</b> pushed once followed by digit 1–9	Selects unit for viewing or changing	Selects unit for viewing or changing
	pushed once followed by digit 0	Selects SCANNING FUNCTION	Selects SCANNING FUNCTION
	pushed once followed by ENTER	Backs up to previous step	
	pushed twice	Prompts for copying or exchanging programs	
<b>B</b>	<b>Mode</b> <sup>†</sup>	Selects MONITOR MODE	Selects PROGRAM MODE
<b>C</b>	<b>Clear</b>	Clears entries so changes can be made	Clears errors; temporarily disables BAD1 and BAD2
<b>D</b>	<b>Hold</b> pushed once	Programs a hold, or soak, at a specified temperature	Holds oven at current temperature
	pushed twice	Programs looping feature	
<b>E</b>	<b>Enter/Start</b>	Enters or reviews a program	Starts, restarts, or skips steps in a program selected by digit <sup>‡</sup>
<b>F</b>	<b>Cancel</b> followed by digit <sup>‡</sup>	Erases the entire program	Cancels a program and returns to IDLE

NOTE: All units can be operating simultaneously regardless of which unit operations are being displayed or which unit is being programmed.

<sup>†</sup>Proportioning GB5s have two monitor modes, one that displays power level and one that displays time. Pressing MODE advances along the cycle PROGRAM MODE → MONITOR TIME MODE → MONITOR POWER LEVEL MODE → PROGRAM MODE → . . . .

<sup>‡</sup>This digit is required by the Confirmation Sequence; see section 2.5, page 12.

Figure 2.2: Keyboard Functions

6–9 do not correspond to real ovens, there is no monitor mode for them. They will always appear in the PROGRAM MODE.

Another, less frequent use of Button A is in copying and exchanging programs. For this use, you must be in PROGRAM MODE. Pushing Button A twice will call up LS-LS or LL-LL, prompting you to specify a program number to exchange or copy, respectively. This is explained in section 3.4, page 19.

**Scan Function:** The GB5 has a special SCAN FUNCTION, where it monitors all five units and displays each unit's time and temperature for a few seconds. This allows you to monitor all your ovens without having to step through them manually. To select the SCAN FUNCTION, press Button A followed by Button 0. The SCAN FUNCTION automatically sets the GB5 to MONITOR MODE. To return to the normal control mode (and reactivate the keyboard), select any unit or program for display by pressing Button A followed by a digit. No buttons other than A are active while Scanning.

Note that whenever the GB5 resets, it automatically invokes the SCAN FUNCTION. In particular, if there has been a power outage, the GB5 will commence Scanning upon the return of power. Other events that will trigger the SCAN FUNCTION are the occurrence of an error related to a specific oven (such as CoLD, BAD1, *etc.*) or the receipt of a command from a PC through the serial communications connector, if you have the optional communications software. As above, the keyboard will be mostly disabled; you will have to select a specific unit or program before you can do anything else, including clearing an error.

**Button B—Mode:** Button B is used for switching between MONITOR and PROGRAM MODE. The mode you select is indicated by a light on either side of the STEP LED: red for PROGRAM MODE, green for MONITOR MODE.

For channels with proportional control, there are two MONITOR MODEs, one showing the power level instead of the remaining time (see section 2.4, page 8).

MONITOR MODE is used for observing the status of any of your five units. A unit must be in MONITOR MODE to perform any of the following functions:

- Display the current settings and status of the unit.
- Start a program (see "Button E").
- Initiate a non-programmed hold (see "Button D").
- Skip a step in the program that is running (see "Button E").
- Cancel the cycle (see "Button F").

When the GB5 is in PROGRAM MODE, you can enter, review or change the times and temperatures (which constitute your temperature profile) for the currently displayed unit. As you enter times and temperatures into the profile, the step you are modifying is displayed in the STEP LED. You may review or change a program even while it is running. Simply press Button B twice to review the program for the unit currently being displayed. See section 3.3, page 18, for details on changing time and temperature settings.

**IMPORTANT NOTE:** Do not attempt to change the step that is currently being executed as this may cause your unit to return to IDLE.

**Button C—Clear:** Button C is most commonly used when the GB5 is in PROGRAM MODE to allow entries to be changed. In MONITOR MODE, Button C is used to clear or retard various error indications.

In PROGRAM MODE, Button C is used to clear entries that you need to change. If only a time has been entered, then pushing Button C clears it. If both a time and a temperature have been entered in a step, pushing Button C once will clear only the temperature. If you do not want to change the time, you then can enter a new temperature setting. If you do want to clear both the existing time and temperature setting, push Button C twice; the first time to clear the temperature, the second to clear the time. You then can enter your new settings. While altering a profile during review, there is no way to clear the time without first clearing the temperature.

**NOTE:** If your display reads all “E”s (error in entry), you must push Button C in order to proceed. (See section 3.2, page 17, for a further explanation.)

In MONITOR MODE, pressing Button C when an error is present simply clears the error. However, pressing Button C when no error is present disables abnormal temperature warnings (BAD1, BAD2) for 45 minutes from the last time it was pushed. This allows you to open your oven and insert a piece or “crash cool” without unnecessarily triggering an error message. This is discussed in more detail in section 4.4, page 30. When you press Button C in MONITOR MODE, both the TIME and TEMPERATURE displays momentarily show a series of dashes “---” to acknowledge the button press.

**Button D—Hold:** Pushing Button D when the GB5 is in the MONITOR MODE immediately initiates a hold, called a “keyboard hold”. This means that the timer for that unit stops and the elapsed time does not advance beyond its present reading. The unit will be maintained indefinitely at the temperature displayed when the button was pushed.

When a hold is started, the yellow HOLD light (to the left of the keyboard) will come on. To resume normal operation, push Button E and then press the number of the unit being displayed.

While in PROGRAM MODE, Button D programs a hold (also known as a “soak”), at a specified temperature, but for an undetermined time. Once the button is pushed, the programmed hold is indicated by “H”s in the TIME display. The temperature is specified in the normal manner (see section 3.2, page 17). When the HOLD is encountered in the course of running the profile, the unit will continue to hold forever or until you release it by pushing the enter sequence (whichever comes first!) Do not use this button for a timed soak (see section 3.1, page 17). When a programmed hold step is reached, the TIME display will show “HHH HH”.

You can start a program with HOLD. You then can attend to other business while your unit reaches working temperature. Once you load the unit, push Button E followed by the unit number, and the GB5 continues with the rest of the curing cycle for that unit. Of course, it has continued to monitor and control all running units during this time.

Button D also is used to program the special looping feature. Simply push Button D twice in succession while in the PROGRAM MODE. (See section 3.5, page 20, for a more complete description of the looping feature.)

### Confirmation Sequence

The functions described below, activated by Buttons E and F, are used to start your units, skip steps in your programs, erase your programs, or reset your units to STEP #1. Because of the importance of these functions, a special sequence is incorporated to avoid accidental use. After pressing Button E or F, you must push the number of the unit currently displayed. Pushing any other button after Button E or F will violate the *Confirmation Sequence* and thus prevent the action. For Button E, the Confirmation Sequence is required only when the GB5 is in MONITOR MODE. For Button F, the Confirmation Sequence is always required whether the GB5 is in MONITOR or PROGRAM MODE.

**Button E—Enter/Start:** Button E serves a different function depending on the mode of the GB5: in MONITOR MODE, Button E is the start/skip-step button; in PROGRAM MODE, it serves as the enter button.

Before starting your programmed profile, make sure the red IDLE and the green MONITOR MODE lights are lit and you have entered your program. Then, push Button E and press the number of the unit displayed in the upper left corner (UNIT). The red IDLE light will go out and the green RUN light will come on, showing that your program has started.

At any time during the cycle you may cancel a given step and go on to the next step (this is called “skip-step” capability). Push Button E and then press the number of the unit displayed. The GB5 will skip to the next programmed step. Once you have skipped a step, there is no direct way to back up. However, you can always cancel the whole program (Button F), restart the program and skip to the beginning of any step.

Button E also is used to continue your program from HOLD. Leaving a programmed HOLD is, after all, nothing more than skipping to the next step.

Recall that the GB5 also has a second kind of HOLD, the keyboard hold, which you can recognize because the yellow HOLD light will be on, but the TIME display will not show “HHH HH” but rather it will be stopped at the time you invoked the keyboard hold. Pushing Button E followed by the unit number will simply cause the program to continue from where it was stopped: the HOLD light will go out and the time will resume counting down.

When the GB5 is in PROGRAM MODE, Button E is used to enter the times and temperatures you select for your program. The Confirmation Sequence feature is not in effect in this mode. After selecting any time or temperature, you must press Button E to record your entry into the GB5’s memory. Then, proceed to your next entry.

Button E also is used to review your program. Each time you push Button E, the next time and temperature set-points appear in the LED displays. Pushing Button A followed by Button E backs up to the previous step. See section 3.3, page 18, for further information on reviewing a program.

**Button F—Cancel:** Button F either cancels or erases a program, depending on the mode. In MONITOR MODE, it is used to cancel a program and return the GB5 to IDLE. This does not erase your program; it shuts the displayed unit off and returns it to STEP #1.

In PROGRAM MODE, Button F erases your entire program.

In both MONITOR and PROGRAM MODE, once you press Button F, remember to follow this by entering the number of the unit displayed, as required by the Confirmation Sequence feature.



# Chapter 3

## Programming

### 3.1 Introduction

A profile for the GB5 may be thought of as a series of points, with each point consisting of a time and a temperature. When these points are connected by straight lines, they form a continuous graph. This graph represents the temperature profile you want your oven to follow. You program your GB5 by entering these time-temperature points. The time you enter is always the length of the step; the temperature is in degrees. Your GB5 automatically calculates the rate (“ramp”) at which the temperature rises or falls between successive time-temperature points.

Some people are used to being forced to describe temperature profiles in terms ramp rates up and down, expressed as degrees per minute, and in terms of timed soaks. The GB5 relieves you of the calculations required to specify profiles in this arcane manner.

For example, your oven is at 100°. In 2 hours, you want it to reach 500°. Then, in 3 more hours you want your oven to be at 650°. The only information you must enter is the two time-temperature points: 2 hours, 500°; and 3 hours, 650°. The GB5 then calculates and executes the ramp up between 100° and 500° in 2 hours, as well as a different ramp rate up from 500° to 650° in 3 hours.

A profile may consist of up to 15 such points, each of which is called a *step*. If you wish to hold a specific temperature for an indefinite period of time, you can use HOLD (see page 11). The HOLD acts as a substitute for a time setting. During a HOLD, the timer does not run, so there is no remaining time period to display. Instead, the GB5 displays “HHH HH”. When you are ready to continue with the program, you have to advance the GB5 to the next step manually (see page 13). A programmed HOLD counts as one step.

The typical use of HOLD is to keep an annealing oven at a fixed temperature while a batch of work is completed. When each piece is finished, it is placed into the annealer,

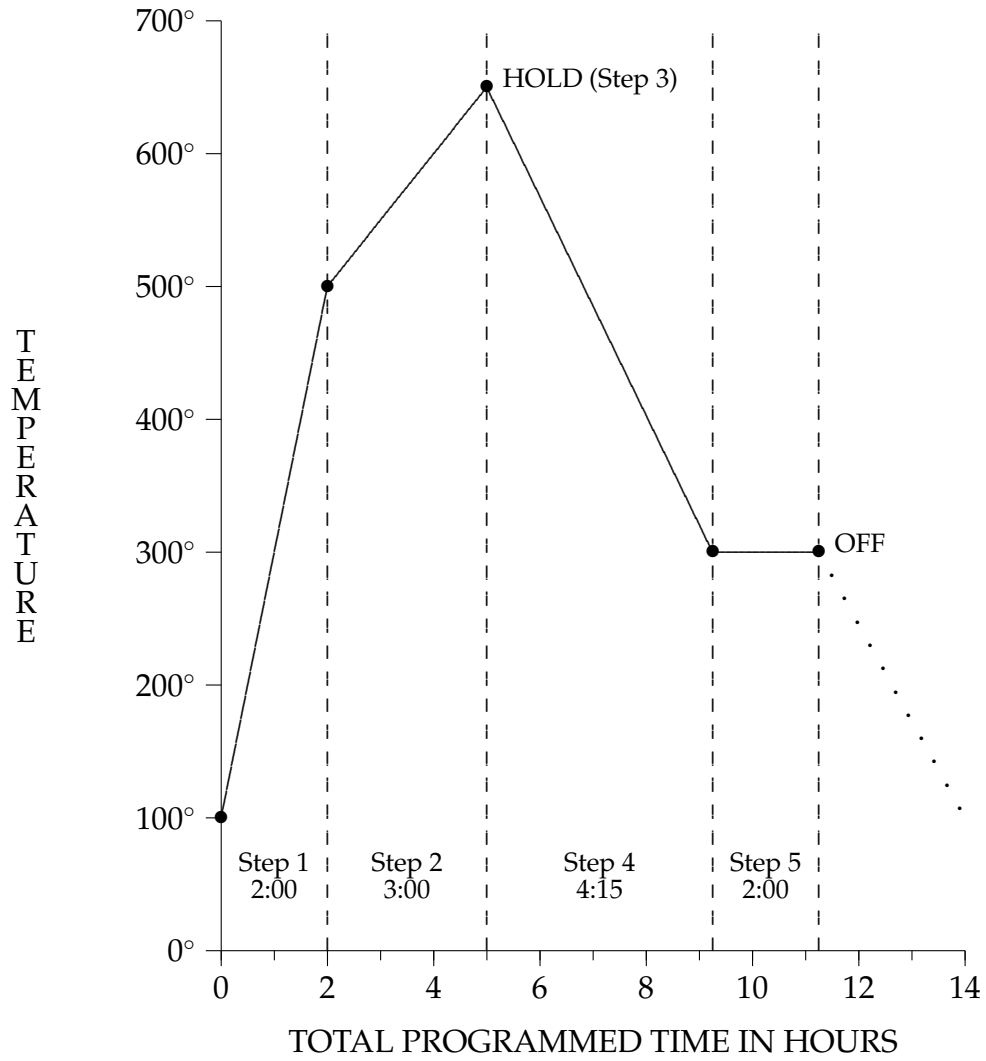

Figure 3.1: Simple Profile



which is maintaining a constant temperature. When the all the pieces are finished (or the annealer is full), then the rest of the annealing cycle can commence. This is when you leave the HOLD step and proceed with the rest of the profile. Since you don't know in advance how long it will take to make the pieces, it is more appropriate to use a HOLD than a timed soak. That way, you will not be working against the clock.

If you wish to maintain a certain temperature for a specific time (a "timed soak"), you simply program it in the standard manner, using the same temperature for two consecutive set-points. For example, the following program ramps up to 950° over an eight hour period and then soaks at 950° for two hours before shutting off.

```

800  Button E (ENTER/START)  (eight hours)
950  Button E (ENTER/START)  (950°)

200  Button E (ENTER/START)  (two hours)
950  Button E (ENTER/START)  (950°)

```

As you can see, you should not use the HOLD button for a timed soak.

Now that you are familiar with the HOLD function, let's add three more steps to the previous example. Your third step is to HOLD at 650° for an indefinite amount of time. Then, cool off to 300° in 4 hours and 15 minutes. Finally, hold at 300° for 2 hours. The third step would then have "H" for time and 650° for temperature. The fourth step would have 4 hours and 15 minutes for time, and 300° for temperature. The last step would have 2 hours for time and 300° for temperature.

The graph in Figure 3.1, illustrates the profile corresponding to this simple program.

A second sample profile is shown in the graph of Figure 3.3. Figure 3.4 shows you just how easy it is to program your GB5 to follow this profile.

## 3.2 Entering a Program

First, select the unit to be programmed by pressing Button A and the unit number (from 1–9) on the keyboard. For units 6–9, the GB5 automatically switches to PROGRAM MODE. For units 1–5, you must put your GB5 into PROGRAM MODE using Button B.

At this point, the STEP display will read "1" and the TIME display will read "0". Now, punch in the time (in hours and minutes) on the keyboard. Then press Button E to enter the time. At this point, "0" will appear in the TEMPERATURE display. If you wish to change the time, or if you have made an error, press Button C (Clear). The TEMPERATURE will become blank and the TIME will read "0". You can now enter a

new time. Then, punch in a temperature<sup>1</sup>After pushing button E, the TIME will read "0" and the TEMPERATURE will be blank. The STEP will read "2".

You now are ready to enter the second point in your program. This process is repeated until you have entered your entire program. Remember, you have as many as 15 steps to work with for each unit. If you enter fewer than 15 steps, your program will terminate upon reaching the first unfilled step (zero time).

NOTE: When your profile has finished running, the GB5 will go into IDLE MODE and, to indicate that the profile has finished, the STEP display will show one more than the last step of your profile, and the TIME display will show zero time remaining. For example, when a profile with 5 steps has completed, the IDLE light goes on, the STEP display shows "6", and the TIME display shows "0". Similarly, when a profile with ten steps has completed, the IDLE light goes on, the STEP display shows "b" (which looks similar to a "6"), and the TIME display shows "0". If you press Button F, the display will change to show a STEP of "1", with the TIME replaced by dashes.

### 3.3 Reviewing a Program

Switching from PROGRAM MODE to MONITOR MODE, and back to PROGRAM MODE (by pressing Button B), automatically sets the STEP display to Step # 1. The time and temperature settings you selected for the first step now will be displayed. Pushing Button E (Enter) advances you through the succeeding steps of your program. Pushing Button A followed by Button E backs up to the previous step. You may review your program in this manner even while the program is running.

At any time during your review, you may make changes to your program by first clearing and then reentering new times and temperatures. However, it is generally not advisable to change the program for a unit that is currently running. If you choose to do so, be sure you do not change the time of the step that is currently being executed. This is because changing a time entails returning the time to zero which, in turn, will terminate your program and put the GB5 into IDLE for that unit.

NOTE: To change the time setting in your program, you first must clear the temperature by pressing Button C once. Then you can clear the time by pressing Button C again. This step of your program now is ready to enter a new time and temperature. If you want to change only the temperature, just push Button C once and the time will remain unchanged.

---

<sup>1</sup>The maximum temperature for Type K thermocouples is set to 2350°F (1250°C); for Type R and Type S thermocouples, the maximum temperature is set to 3000°F (1650°C). Attempting to enter a temperature above the maximum causes E's to appear, indicating an error. If this happens, push CLEAR to proceed.

## 3.4 Copying and Exchanging Programs

As mentioned in section 2.5, page 8, units 6, 7, 8, and 9 have no hardware attached to them; you may think of them as “phantom ovens”. However, they may be programmed just as the ovens 1–5 are. Since there are no temperature inputs or relay outputs for these phantom ovens, you cannot run them. There is nothing for them to do except to store extra programs for future use. The programs in 6–9 are entered, reviewed and edited (changed) just as those in one through five. To use one of these programs, you must copy it into unit 1, 2, 3, 4, or 5 as described in the following paragraphs. To simplify the language in what follows, we will call the program for unit 1, “program 1”, etc.

You can exchange any two programs with just a few button pushes. You can also copy (replicate) a program into a completely blank program. You will be notified whether a copy or exchange is to occur by the symbols in the TIME display: “LS-LS” for exchange or “LL-LL” for copy.<sup>2</sup> With regard to copying and exchanging, all programs 1–9 are on equal footing. You may copy (or exchange) from any one to any other.

Now for the details:

- First select your target program with Button A as usual. Put unit in program mode if it is one of 1–5. (Units 6–9 will automatically be in program mode.)
- If you want to copy another program into the target (as opposed to exchanging another program with the target program), you must first completely clear the target program. This means that all 15 steps must be zero. If only the first few steps have been cleared, the program may seem empty without being so. If you get the LS-LS symbol, you can be sure that one of the 15 steps has data in it. Using Button F, you can clear all steps without having to explicitly find the non-zero steps. If your target is not totally cleared, it will be exchanged with the source program. In other words, if you are not careful here, you will find that the source program has changed when you did not expect it to do so.
- Now push Button A twice in a row. The appropriate symbol, LL-LL or LS-LS, will appear in the TIME display and a dash will appear in the TEMPERATURE display. This dash will turn into the source program you wish to load or copy from when a digit (1–9) is pressed. If any other button is pushed, you will get an error (“E”s will appear in the TIME display), and then you need to push Button C (Clear Entry) and start again. You may change the number without first clearing it; just push a different one.

---

<sup>2</sup>While these may not be the most obvious symbols, bear in mind that only a limited number of possible characters exist for the display. It may help to think of the exchange symbol as “load and store” and the copy symbol as “load”.

- After having chosen the source program, push the enter key. Voilà... the exchange or copy will take place! Note that when you do two exchanges in a row, you will be back to where you started. If you do a copy, the source program will remain where it is and also be replicated in the target program. We note the obvious fact that if you exchange two programs which are exactly the same, it is equivalent to having done absolutely nothing!
- Also note that it is impossible for one program to overwrite another—they merely interchange themselves. If you want to overwrite the target, you must first wipe it out with Button F and then copy over the blank program.

### Summary

- Target program completely empty means you will replicate the source program into the target. The symbol is “LL-LL”.
- Target program not completely empty means the source and target will be exchanged. The symbol is “LS-LS”.

## 3.5 Looping

Many people use a Type S channel to control a furnace. Unlike an annealer, a furnace usually runs on a repetitive, continuous cycle. To accommodate such use, the GB5 contains a loop command which allows indefinite repetition of a temperature profile. After reaching the last programmed step, the program immediately will return to Step #1. When the repeat feature is operational, the program will never stop by itself. The repeat can be cancelled by pressing Button F or removed by changing your program.

The loop command can be used only once in a program. It always sends the program back to the very beginning. It is invoked from the PROGRAM MODE by pushing Button D twice in succession. The “H”s and blanks in the TIME and TEMPERATURE displays will change. The TEMPERATURE display will read “LOOP” and the TIME will have dashes. When this occurs, press Button E. (Failure to do this will result in an error. You then must clear the step by pressing Button C and start this step over again.)

When Button E is pushed, the display will show all horizontal bars indicating that no further program steps may be entered, regardless of what the STEP display reads. This is because the loop is always the last thing you do. Pushing Button E at this point will have no effect. You can gain access to the remaining program segments by clearing “LOOP” (press Button C). If you push Button E after pushing Button D just once, the GB5 will assume that it is a HOLD. In this case, a subsequent push of Button D will be

ignored, since the GB5 is expecting a temperature. In short, the sequence of buttons to be pressed is:

For a HOLD: D, E, (temperature)

For a LOOP: D, D, E

When set on a 24-hour cycle, the times may slowly “creep” over a period of days. A unit set to come on at 8:00 a.m. gradually will come on later in the day. There are several reasons for this. First, due to technical constraints, the GB5’s internal clock is off by about 15 seconds a day. Although this amounts to only about 2 minutes a week, it eventually will add up. Second, anything that stops the timer, such as power failures (which may well go unnoticed because of the GB5 Memory Back-up) or pushing Button D (HOLD), will delay the cycle. Third, if the unit goes into AUTO-HOLD for any reason, the cycle will be delayed.

When using the looping feature, the current unit temperature is read as the starting point for calculating the temperature slope on the first segment of the profile. Thus, if your unit temperature is hotter during the second run of the cycle, there will be a less steep ramp than the first time.

For example, assume your first step is to raise the temperature to 700°F (371°C) in one hour, then go to 1100°F (593°C) in 3 hours before entering the looping feature. The second time around, your unit will start out at 1100°F and the GB5 will take it down evenly to 700°F in one hour. This may or may not be what you intended.

If you want the repeat to start from some cool point, you must specifically put that into your program. For example, if you want your cycle to always ramp up to 700°F from a maximum of 300°F (149°C), you must enter a cooling off segment in the program before the loop. If this segment is too short for the unit to cool down within the allotted time, then AUTO-HOLD will come on, changing your total cycle time.

## 3.6 Delayed Start

The GB5 has a *delayed start* feature. The main use of this is to have your oven waiting for you at working temperature when you arrive at your studio in the morning. With the GB5, you do not have to leave the oven on all night to accomplish this, thus saving on your fuel bill and your time. All you have to do is set the first step of your profile to zero temperature and set the time to indicate the amount of time that should elapse before the oven should begin to heat.<sup>3</sup> Then set the second step to HOLD at the desired morning temperature. Be sure to start the HOLD soon enough to allow the oven to attain desired temperature before you need to use it.

---

<sup>3</sup>Whenever the programmed temperature is set to zero, the GB5 will run its clock without turning on the oven and without engaging AUTO-HOLD.

For example, if it is 7:30 p.m. and you are ready to go home, but you want your unit to come on at 7 a.m. the next morning so that it will be nicely hot (say 950°) by 9 and then hold that temperature, you could enter a three-step program:

Step	Time	Temperature	Comment
1	11:30	0°	11:30 hours from 7:30 p.m. is 7:00 a.m.
2	2:00	950°	2:00 hours from 7:00 a.m. is 9:00 a.m.
3	HOLD	950°	

Alternatively, you could heat up as quickly as possible to 950° starting at 8:00 a.m. by entering the following slightly simpler program:

Step	Time	Temperature	Comment
1	12:30	0°	12:30 hours from 7:30 p.m. is 8:00 a.m.
2	HOLD	950°	AUTO-HOLD will come on while the kiln heats up to 950°.

### 3.7 Sample Program

To end this chapter, we include an example of a typical program. A sample profile is shown in the graph of Figure 3.3. This profile shows the unit starting at room temperature (around 70°F) and ramping up to 650°F in 2 hours 45 minutes. It then soaks for three hours and then ramps up to 1050°F over the next seven hours, where it soaks for two hours 15 minutes. After that, it ramps up to 1200°F over one hour and then immediately ramps down to 350°F over the next seven hours. This ends the program, so the unit will then shut off and coast down to room temperature. Figure 3.2 shows this program filled in on a Digistry GB5 Programming Form. Blank forms may be found at the end of this manual or obtained from Digistry Company, Inc.

The sample program in Figure 3.4 shows you just how easy it is to program your GB5 to follow this profile for unit #5. By pushing the buttons indicated, you can enter this program into your GB5.



Copy Freely &  
Use Genuine Digitry Controllers

## Digitry GB5 Programming Form

Oven # \_\_\_\_\_ 5 \_\_\_\_\_

Date \_\_\_\_\_ 3/29/2005 \_\_\_\_\_

Use \_\_\_ *Sample Profile* \_\_\_

Author \_ *Leslie Cooper* \_

	Step 1	Step 2	Step 3	Step 4	Step 5
Temp	650	650	1050	1050	1200
Time	2:45	3:00	7:00	2:15	1:00

	Step 6	Step 7	Step 8	Step 9	Step A
Temp	350				
Time	7:00				

	Step B	Step C	Step D	Step E	Step F
Temp					
Time					

Notes:

Figure 3.2: Filled In Programming Form

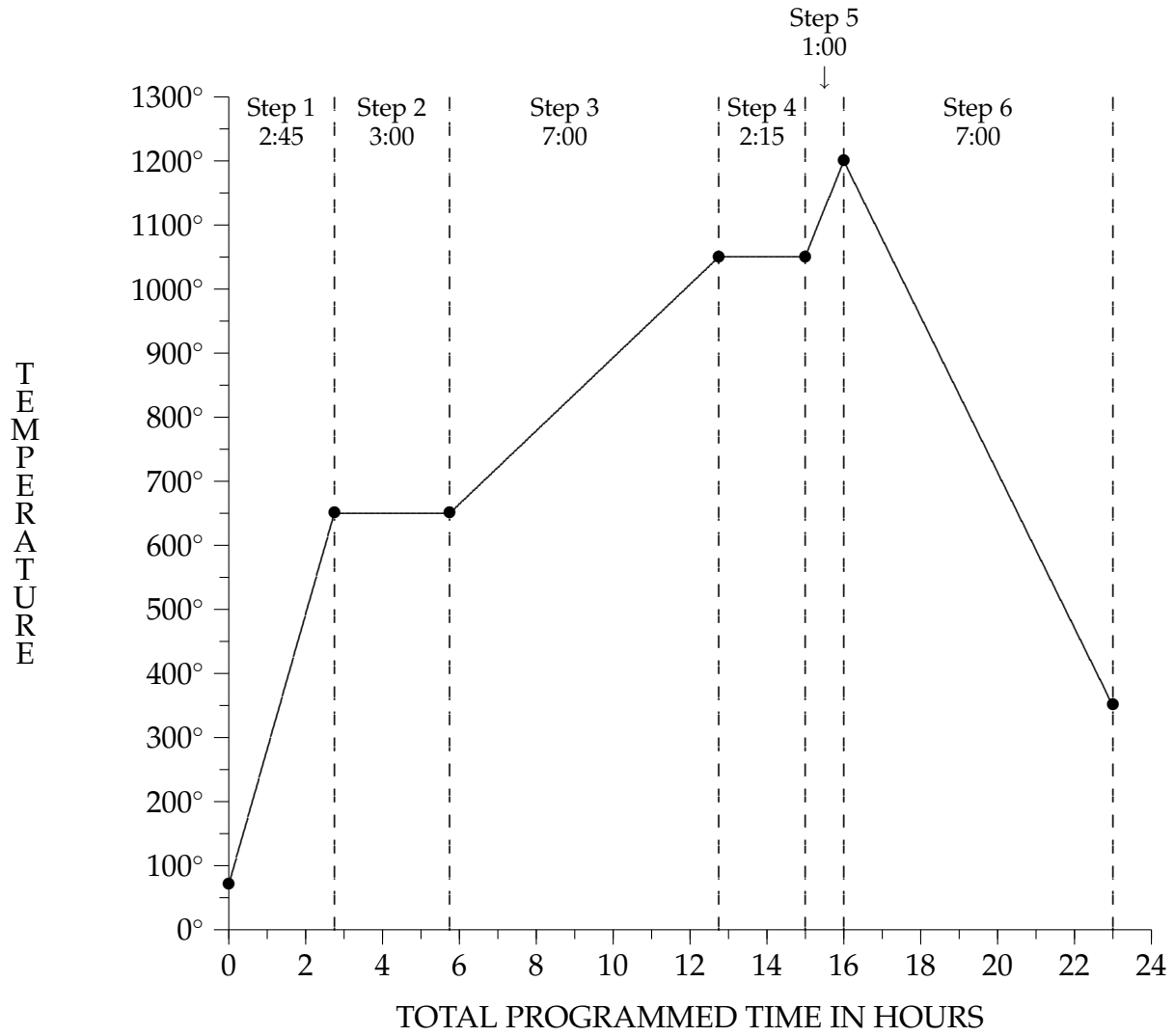

Figure 3.3: Sample Profile Graph



Press:	To:
A 5	Let the GB5 know you want to program unit #5.
B	Put the GB5 into PROGRAM MODE.
245 E 650 E	Program unit #5 to ramp up evenly to 650°F in 2 hours and 45 minutes. This is Step #1.
300 E 650 E	Soak at 650°F for 3 hours. This is Step #2.
700 E 1050 E	Ramp up to 1050°F in 7 hours. This is Step #3.
215 E 1050 E	Soak at 1050°F for 2 hours and 15 minutes. This is Step #4.
100 E 1200 E	Ramp up to 1200°F in 1 hour. This is Step #5.
700 E 350 E	Ramp down to 350°F in 7 hours. This is Step #6.
	The program is now entered.
B	Return to MONITOR MODE.
E 5	Start unit #5 running.

Figure 3.4: Sample Profile



# Chapter 4

## Special Features of the GB5

The GB5 is designed with several special features to enhance its ease of use and reliability. These include

- stretching the length of steps to meet the capabilities of your oven using automatic holds,
- warnings of common external failures (thermocouple burn-out, contactor lock-up, etc.),
- preservation of your programs in the event of a power failure, and
- monitoring of memory integrity.

### 4.1 Automatic Hold

Using the program you entered, the GB5 calculates a temperature for each minute of the cycle. It bases its decision about automatic holding on this temperature. Essentially, if your unit is not able to keep up with the temperature changes you requested, the GB5 clock for this unit will be stopped until the unit catches up.

On heating steps (ramping up), the AUTO-HOLD light will come on if the unit temperature is more than 40°F (20°C) below the calculated temperature for the current minute. On cooling or soak steps, the AUTO-HOLD light will come on whenever the unit temperature exceeds the calculated temperature for the current minute by more than 40°F (20°C).

Once the AUTO-HOLD is engaged, it keeps the clock stopped until the temperature calculated for the current minute is actually achieved.

Under normal circumstances, AUTO-HOLD is usually thought of as something that compensates for unusual demands placed on your oven's ability to follow a profile.

However a creative use of AUTO-HOLD allows you to program your oven to ramp up to a given temperature as quickly as possible. Simply program the time for the step to be one minute. The GB5 then will go into AUTO-HOLD until the desired temperature is reached and then go on to the next step.

## 4.2 Guaranteed Temperatures

Sometimes it is very important that the final temperature of a ramp be attained before going on to the next step of the profile. So, at the end of each step, the GB5 guarantees that the oven actually reaches the programmed temperature before allowing it to go on to the next step. When necessary, the clock will be stopped during the last minute of a step to allow the oven to reach this temperature. The AUTO-HOLD light will come on while the clock is stopped.

## 4.3 Error Messages

There are certain serious problems that could cause improper temperature readings or overheating of a unit. When this happens, an error code of the form “BAD?” or “ERR??” will appear in the display to identify the problem. The difference between a BAD and an ERR messages is this: BAD refers to a problem with a specific channel while ERR concerns a problem that affects all channels.

The “BAD?” or “ERR??” display is made up of unusual-looking characters. “BAD” is a lower-case b, an upper-case A, a lower-case d, and then a single digit. “ERR” is an upper-case E, two lower-case r’s, and then two digits. We mention all this because the messages can be very confusing when first seen, and we hope you see them seldom enough that you never get used to them!

When it detects an error specific to a given channel (one of the “BAD” messages), the GB5 will attempt to shut down the corresponding unit by turning off its contactor<sup>1</sup>. It will also start the special SCAN FUNCTION (see section 2.5, page 10), to guarantee that the affected unit will show up in the display.

Switch to the unit by pressing Button A, followed by the unit number, and then press the CLEAR key, Button C. This will clear the BAD message and allow the GB5 to resume the corresponding program. However, if the condition has not been corrected, the error message will be reactivated as soon as the condition is again detected. This can take anywhere from one second to twenty minutes, depending on the cause of the problem. Of course if the error messages have been disabled, as discussed below, then

---

<sup>1</sup>Depending on the problem, the GB5 may not be able to shut off the contactor. For example, the underlying problem may be that the contactor itself has failed in the “on” position.

BAD1 and BAD2 are prevented from occurring for at least 45 minutes. As a special option, GB5s may be ordered with BAD1 and BAD2 both permanently disabled, on a channel-by-channel basis.

These are the various error messages and their interpretations.

**BAD1:** The temperature does not appear to be increasing, even though the GB5 is calling for heat. This error message latches on until the CLEAR key, Button C, is pushed. Likely causes of BAD1 are

1. The thermocouple has come out of the oven.
2. There is a bad fuse in GB5 output module circuit.
3. The contactor is bad (its coil has probably burned out).
4. There is a fault in the oven itself that prevents it from heating adequately.
5. There is an internal problem in the GB5.

**BAD2:** There has been a significant temperature increase even though the GB5 is not calling for heat. This error message latches on until the CLEAR key, Button C, is pushed. Likely causes of BAD2 are

1. The contactor is bad (it has become stuck or shorted).
2. There is a short circuit in the wiring between the GB5 and the contactor.
3. There is an internal problem in the GB5.

**ERR10, ERR24, ERR28:** The GB5's internal circuitry has detected an evanescent error, probably caused by environmental electrical noise. If this happens repeatedly, you may need a power line conditioner.

**ERR21** The line voltage has dropped below that required for reliable operation of the GB5. The GB5 will shut itself down until the line voltage is restored.

**ERR4?** This error occurs when there is a timing problem in the serial communication.

**ERR5?, ERR60, ERR70:** These all correspond to internal errors internal problems with the analog to digital converter. If the first digit is 5, the second digit helps Dig- itry locate the cause of the difficulty. However, the error can also be caused if the temperature appears to be over the maximum the GB5 is capable of reading (ap- proximately 2385°F for Type K). This warning remains active only so long as the problem is detected; once the problem disappears, the error clears itself.

Note that the error messages BAD1 and BAD2 “latch on” and will only reset when CLEAR is pressed. The other error messages are self-clearing, but if the problem recurs frequently, they will appear to latch on.

Another form of error message is the “buzz” that a sending unit for a Type K thermocouple makes when either the thermocouple burns out or is disconnected. Note that it is normal for thermocouples to burn out after a certain amount of use. If you are using a Type K thermocouple, the Sending Unit will buzz when this happens. As described in the troubleshooting section 8.1, page 62, you should try connecting a plain piece of wire from the red to the yellow terminals where the thermocouple attaches. If this stops the buzzing, then the GB5 is functioning correctly, and you should replace your old thermocouple. Of course, you should remove the wire used during testing when you connect a thermocouple.

## 4.4 Disabling Error Messages

BAD1 and BAD2 signify temperature changes not initiated by the GB5. Under normal circumstances these work as expected. However whenever external events cause abrupt temperature changes, these errors may falsely trigger. This could happen when you place a large, hot casting into the oven; it might raise the temperature without the GB5’s calling for heat, thus triggering a BAD2. Similarly, opening the oven door to place a piece into the kiln or keeping it open to “crash cool” a piece could trigger a BAD1. Under these circumstances, it is desirable to be able to disable the error messages before they alarm you and disrupt your work!

Pressing the CLEAR key while the GB5 is in MONITOR MODE has the effect of disabling the BAD1 and BAD2 error messages for 45 minutes. Any time it is pushed, the 45 minute delay begins afresh; pushing it twice does not give 90 minutes — just 45 minutes from the second push. The key is acknowledged by momentarily displaying a horizontal bar “— — —” in both the TIME and TEMPERATURE displays. In general, there is no way to cancel this delay but the passage of time.

## 4.5 Behavior During Power Failures

Special components and circuitry are used within the GB5 to preserve its memory during power failures. The GB5 will remember:

- which units were running and which were idle when the power failed,
- the program step and time of each running unit when the outage occurred, and

- the last temperature reading of each running unit at the time of the power failure.

During the power failure, the face of the GB5 will look blank. When power is restored, "8"s will appear in the TIME and TEMPERATURE displays while the GB5 takes new, reliable temperature readings. Concurrently, the UNIT display counts down from five to one<sup>2</sup>.

The GB5 then evaluates the temperature loss of each unit from the time the power failed to the time it was restored. If the actual temperature loss is less than 200°F (or 100°C for Celsius models), that unit will continue as if the power failure had not occurred. Since the vast majority of power failures are quite short (under one minute), the unit temperature drop is insignificant and the unit thus will continue running according to your original program.

If a unit cools more than 200°F during a power failure, the temperature of the unit when power is restored will be maintained. The TIME and TEMPERATURE displays for that unit will read "Cold". This procedure should protect your unit and its contents from reheating rapidly without your knowledge. When you check the unit and notice this condition, you then have the opportunity to decide the most appropriate course of action from this point (as described in the following section).

After the GB5 has measured the temperature of all units to determine whether the unit should continue running or be maintained at its current temperature, the SCAN FUNCTION will be triggered (see section 2.5, page 8). Note that even a very short power failure will cause the SCAN FUNCTION to be activated.

## 4.6 "Cold" Readings

As noted above, if a power failure has lasted long enough that one of your units has cooled more than 200°F (100°C) during the outage, its TIME and TEMPERATURE displays will read "Cold". The current unit temperature will be maintained, and the SCAN FUNCTION will be activated so the "Cold" will be seen whenever that unit is scanned.

For each unit that is "Cold", push Button A and the number of that unit. The GB5 will go into MONITOR MODE and "Cold" will be displayed. Push Button C to clear the "Cold" display. The last step and time reading for that unit before the power failure will be displayed along with the CURRENT temperature.

If you choose to continue with the program at this point, push Button E (Enter/Start) and the unit number. As the unit lost more than 200°F during the power failure, the unit

---

<sup>2</sup>It is important to realize that many power failures are extremely short, so short that you may not even notice them. As a consequence, from time-to-time your GB5 may appear to count down spontaneously. This is invariably a result of power difficulties of some sort.

will begin heating. If the unit was ramping up when the power failed, AUTO-HOLD will go into effect until the unit reaches the programmed temperature.

If you want to cancel your program and restart the unit, push Button F and the unit number. The GB5 will then be in IDLE.

When "COld" is displayed and the GB5 is in MONITOR MODE, you can examine or change your program by putting the GB5 into PROGRAM MODE. Remember, it is best not to reprogram a unit that is running.

In summary, when "COld" is displayed, push Button A and the unit number. You then push:

- C, E, (unit number) to continue with the program, or
- C, F, (unit number) to cancel the program.

Follow the procedure above for each unit that is marked "COld".

## 4.7 Memory Failure

Your GB5 continually checks its internal memory for accuracy. In case of a memory failure, the green and red MODE lights alternately will light about every one-half second and "P"s (for "Problem") will flash across the TIME and TEMPERATURE displays.

In the event of a memory failure, the GB5 is designed to protect your work and units by running the following sequence. First, it will turn off all units for about one minute to allow the temperature readings to stabilize. Then, it will read the current temperature of each unit and hold at that temperature until you reprogram the GB5.

When the GB5 signals a memory failure, pushing any button on the keyboard will reset it. It then will stop flashing, display UNIT #1, clear all memories and set all units to IDLE. If you do not reprogram the GB5, your units will begin to cool down.

Fortunately, memory failure is quite unusual. It can usually be traced to one of two causes:

- A voltage transient so fast and so powerful that it swamps the GB5's protective circuitry and modifies program memory. Digity's memory assurance scheme is so sensitive that it will detect the alteration of even a single digit.
- Power failure while you are entering a program. In this case, the memory assurance scheme may detect inconsistent information.



# Chapter 5

## Installation

### Safety Considerations

Before installing your GB5, please consider the following important safety issues. Your Digitry temperature controller is a device to facilitate the processes involved in ceramic and glass production. Any electronic device can fail for a myriad of reasons — both obvious and obscure. One should never rely on any temperature controller to ensure fire safety. Any oven (kiln, annealing oven, or furnace) should be installed so that there is no fire danger, even if the oven is on full all of the time (although this might cause damage to the oven itself). Be sure there is adequate clearance from all walls and flammable materials. In particular, floors under ovens should be fireproof. Additionally, your installation should conform to all applicable fire and building codes.

The electrical circuits powering your oven involve very high currents and dangerous voltages. Apart from dangers posed by potentially lethal electric shock, there is also a danger of fire arising from inadequate or improper wiring. Accordingly, it is strongly advised that all electrical work involving the powering of your oven and installation of power relays (mercury or solid-state) be done by a qualified electrician, in compliance with all applicable electrical codes.

### 5.1 Overview

There are two aspects to the installation of your GB5:

- connecting the thermocouples, which measure the temperature of each unit and,
- connecting the relays or other devices that control the heating of the unit.

Review Figure 5.1 on the following page to familiarize yourself with the layout of the back of the GB5. Then read all the following instructions before installing your GB5. As you will see, the entire procedure is relatively easy. Since the connections depend on the type of channel, make sure you use the correct procedure in each case.

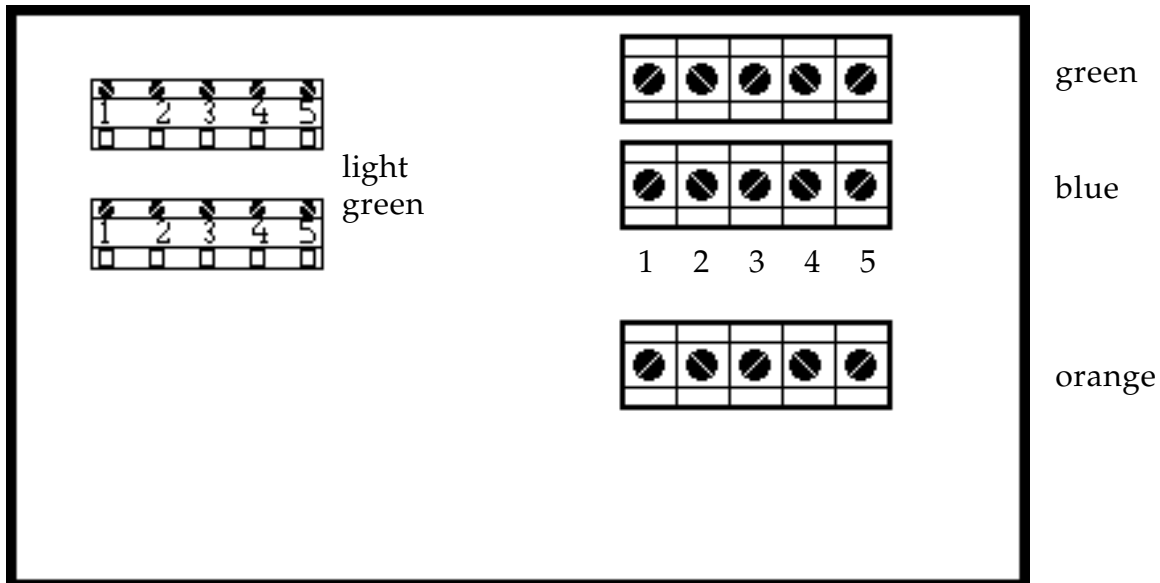

Figure 5.1: GB5 back

## 5.2 Thermocouples

There are various types of thermocouples in common use. For temperatures typical of most glass and ceramic techniques, the Type K (chromel-alumel) thermocouple is almost universally used. For the higher temperatures encountered in certain processes such as crystalline glazing of ceramics and for melting glass in furnaces, a platinum thermocouple<sup>1</sup> is required. Channels of the GB5 can be calibrated for either of the platinum thermocouples, Type R or Type S. Digitry makes two different kinds of Sending Units, one for Type K thermocouples and a second for either of the platinum Type R and Type S thermocouples. Since the Type S thermocouple is used much more commonly than the Type R, we will refer to this Sending Unit as a Type S Sending Unit.

Unless otherwise specified, all channels on a GB5 are configured for use with Type K thermocouples, but each channel can be configured independently for a Type K, Type R, or Type S thermocouple. Because of differences in calibration, the type of thermocouple must be matched with the type of the channel to which it is attached. A GB5 channel that has been configured for a Type K thermocouple should not be used with a Type R or Type S thermocouple, and so forth. A mismatch between the thermocouple and the

<sup>1</sup>Actually, as in all thermocouples, there are two metals involved, platinum and rhodium, but the thermocouple is usually referred to simply as a platinum thermocouple

GB5 will result in erroneous temperature readings but will not damage the GB5.

The thermocouple itself should be situated within the oven so that it is certain to measure an appropriate and reasonably steady temperature. For example, if placed too near the heating element, it may read a temperature that is higher than — and fluctuates much more than — the ambient temperature.

## 5.3 Sending Units

The very weak signal from the thermocouple is amplified by our specially designed thermocouple Sending Unit before being sent to the GB5.

Most customers will have only Type K thermocouples and thus use only Type K Sending Units. Because of differences in calibration, a channel that has been designated as Type S should not be used with a Type K or Type R thermocouple, nor Type K Sending Unit and *vice versa*. A mismatch will result in erroneous temperature readings but will not damage the GB5 nor sending unit.<sup>2</sup>

The only difference between Type K sending units and Type S sending units *as far as their installation is concerned* is in the color coding. In the United States, the standard markings for Type K are Red (for negative) and Yellow (for positive), while Type R and Type S are Red (for negative) and Black (for positive). These directions are written as though you are installing a US-marked Type K thermocouple, with the US Type S color in parentheses where it differs.

If you are unsure about which channels are Type K and which are Type S, you can tell by checking what temperature is displayed when no Sending Unit is attached: Type K channels read 32°F (blank for Celsius), and Type S and Type R channels read in the mid 40°F (a little less than 10°C) range. Rest assured that hooking a Type K Sending Unit to a Type R or Type S channel or vice versa will result in no damage, either to the Sending Unit or to the GB5. However, it will give noticeably incorrect temperature readings; if uncorrected, this could damage the work in the oven.

The Sending Unit should not be exposed to excessive heat [anything greater than 170°F (75°C).]

Your Sending Unit has two terminal strips at each end (see Figure 5.2). The one with two terminals coded red and yellow (black) is for connecting your thermocouple leads. The other has three terminals, colored orange, blue, and green. This is for connections to the GB5 itself. The connection between the Sending Unit and the GB5 is made with common wire (between 20 and 16 gauge hook-up wire is recommended). The longer the distance between the Sending Unit and the GB5, the thicker the wire should be.

It is recommended that you hook up the Sending Unit to the GB5 before connecting

---

<sup>2</sup>The readings will be so abnormal that there will be no question as to whether something is amiss.

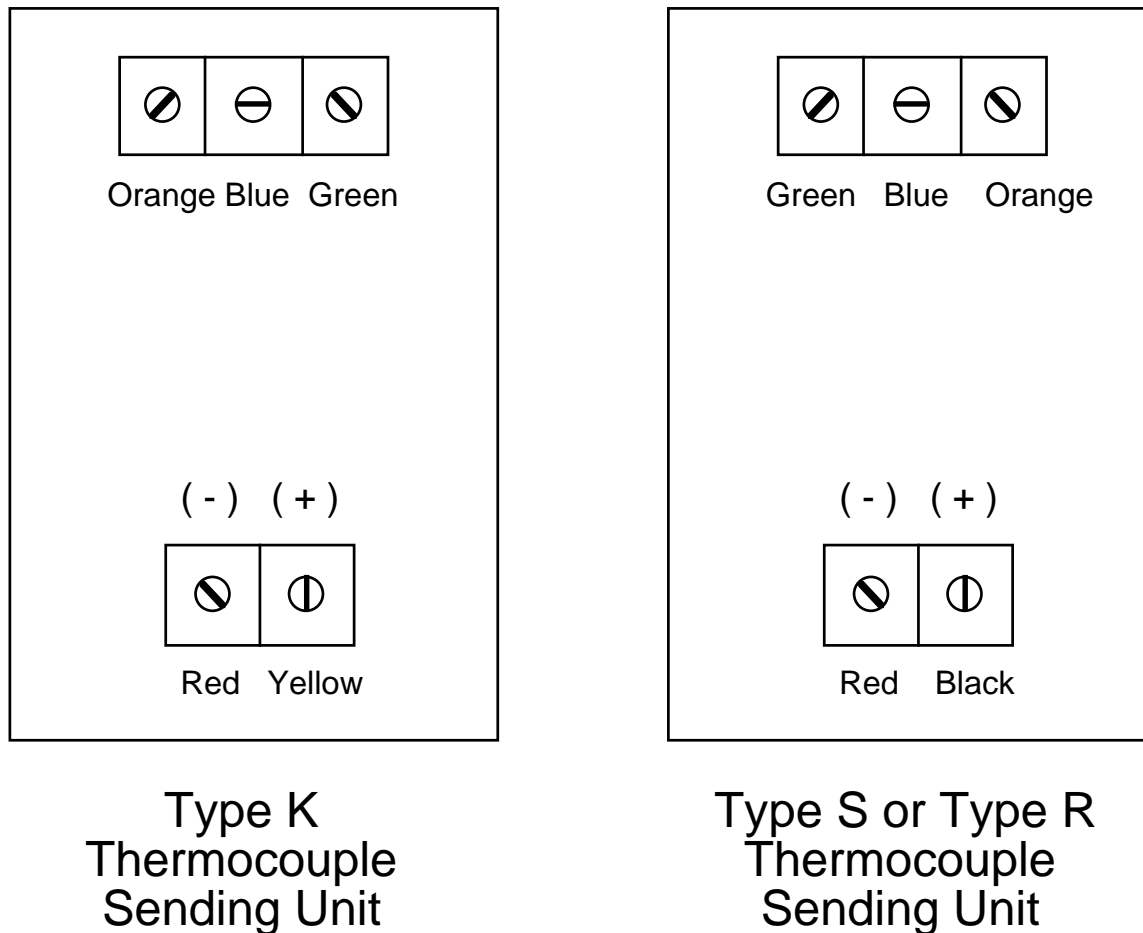

Figure 5.2: Sending Units

the thermocouple to the sending unit. This will allow you to check that these corrections are correct before introducing more variables in the form of thermocouple connections.

To prevent damage from static electricity during shipping, the Sending Unit terminals are shorted together with small jumper wires. These must be removed prior to using the Sending Unit. However, during installation, to test your connections to the GB5 before connecting the thermocouple, leave the jumper between the red and yellow (black) terminals on, but remove the others. Then, when the Sending Unit is correctly connected, the GB5 should read room temperature.

If the thermocouple jumper wire is removed but no thermocouple is connected, the Sending Unit will think there is a burned-out thermocouple. (The sending unit cannot tell the difference between a burned out thermocouple and the fact that there simply is

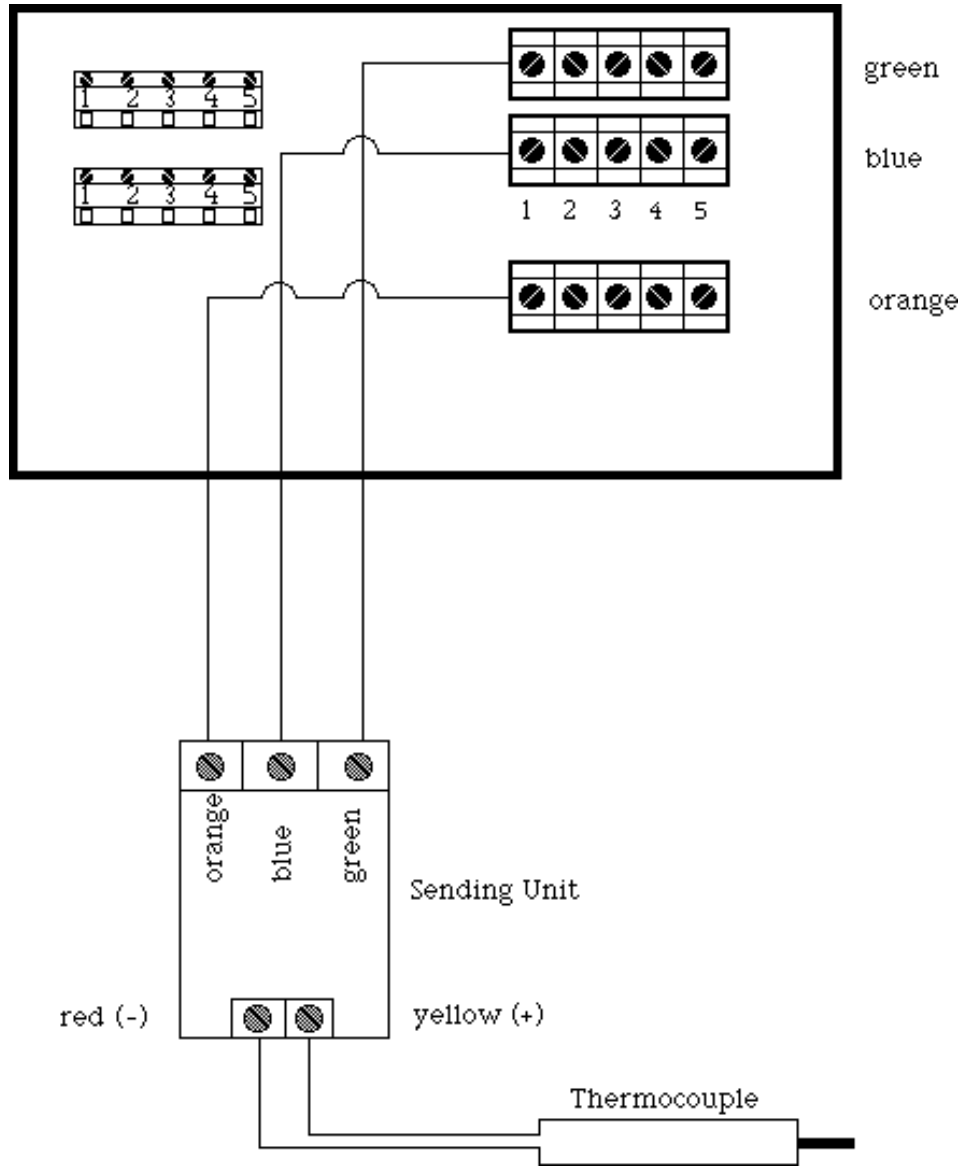

Figure 5.3: Type K Thermocouple Connections

none connected.) In this case, with a Type K Sending Unit, the audio alarm will buzz; there is no audio alarm for a Type S Sending Unit. In case of thermocouple burn-out, the temperature will drift to a very high number that has nothing to do with the actual temperature, and your oven will turn off. When a functioning thermocouple is reconnected, normal operation will resume. Of course, when a thermocouple is connected, any jumper wire must be removed.

As shown in Figure 5.1, there are 5 terminal strips arranged in 2 groups on the back of the GB5. Looking from the back, the 3 strips on the right side are for the Sending Units. The top row is color-coded green, the middle row blue, and the bottom row orange. The top row is for the temperature signals from the Sending Units. The middle row is common, and the bottom strip is for the power to the Sending Units. This bottom strip has +15 volts at every position. Since these are only for power, they do not correspond to any particular channel. The only reason there is more than one screw is convenience. Inside the GB5, all the orange are connected together, and similarly, all the blue are connected to each other.

Reading from left to right, the terminals correspond to channels (*i.e.*, units) 1–5. Connect the Sending Units to the GB5 by attaching the three wires. When making the connections from the GB5 to the Sending Unit, it is very important that the colors match (*i.e.*, orange to orange, blue to blue, and green to green). The order of the colors on your Sending Unit may not match the order shown in Figure 5.2 but the color is all that is important.

When connecting wires between the Sending Unit and the GB5, avoid running them parallel to heavy current-carrying wire (such as the main power lines in your heating elements or relay control power lines)<sup>3</sup>. If these lines run parallel, they can form an electro-magnetic coupling, which causes 60 cycle noise to be picked-up on the temperature input. Frequently, problems involving erratic temperature readings can be traced to a situation such as this.

The next step is to hook up the Sending Unit to the thermocouple. A thermocouple is a polarized device, and it is important to attach it correctly. As noted above, in the US, a typical thermocouple has red and yellow (black) wires that connect to the red and yellow (black) terminals, respectively. On the thermocouple side, the red is negative and the yellow (black) is positive<sup>4</sup>. If your thermocouple is not marked in this manner, you must determine which wire is positive and which is negative. [Try it one way. If you make the wrong connection, the reading will not increase as the thermocouple is heated. Rather, it will go down from room temperature to 32°F (0°C). Type K Sending Units then stay at this temperature no matter how much heat is applied.]

---

<sup>3</sup>In particular, the wires connecting the GB5 and the Sending Unit should not share the same conduit as the main power lines or the relay control power lines.

<sup>4</sup>This may be confusing to those of us who associate red with positive. However, we must accept this inscrutable convention of the thermocouple world.

Connect the yellow (black) thermocouple lead to the yellow (black) terminal screw on your Sending Unit, and the red lead to the red screw. If you hook up the thermocouple with the leads interchanged, no damage will occur. However, the temperature readings will be wrong, as stated above.

Generally you can attach the thermocouple lead wires directly to the Sending Unit, but if you find this is inconvenient, you may use extension leads. These leads should be of thermocouple wire or thermocouple extension wire of the appropriate type (K, R, or S) and should be relatively short. The suggested length of the thermocouple leads or extension is up to approximately eight feet [2.4 meters], but there is no hard-and-fast rule about this. Depending on your situation, you might be able to use leads considerably longer than this, but you will have to make a few experiments to find out. A thermocouple generates extremely small voltages, on the order of a few thousandths of a volt, reaching a maximum of about 50 millivolts. The longer the wires, the more they act like antennas, picking up electrical noise that makes it harder to get correct temperature readings. If you observe unreliable or erratic temperature readings, especially when heavy electrical equipment or motors turn on and off, you should be suspicious of long thermocouple leads.

Ordinary copper wire can be used instead of extension wire, but this generally introduces small errors into the temperature readings. This error is known as “cold-junction error” and is an offset error that depends only on the ambient room temperature.<sup>5</sup> You may decide that this error is small enough — especially compared to the working temperatures you care about — that you can ignore it.

## 5.4 Connecting Outputs

Each channel of the GB5 is set up for one of three possible output types, corresponding to

- a mechanical or mercury contactor,
- a solid-state power relay, or
- a 4–20 milliamp current loop.

The five channels of a given GB5 may have any combination of these output types. Since GB5s are frequently installed in harsh industrial environments, they use optically isolated output circuits to protect the internal circuitry from electrical spikes and transients.

Each output type has a different installation scheme, so be careful to consult the section appropriate for the channel you are connecting. In particular, a channel for a contactor requires connection to an external voltage while the other two forbid connec-

---

<sup>5</sup>An offset error does not increase as the measured temperature gets higher.

tion to any external voltage. So, to avoid damage, be very careful to attach each wire to the correct terminal.

Looking at the GB5 from the back (see Figure 5.1), the two strips on the left side are used for these output circuits. As with the thermocouple inputs, the outputs correspond to units 1–5 when reading left to right.

When connecting a wire to an output terminal, please use an appropriately small-sized screw driver. Our repair department has seen many units that were severely mangled by oversized screw drivers. The output terminals have captive screws, which cannot be individually replaced. If these are damaged beyond use, the entire terminal strip must be replaced. This is, of course, never covered under warranty.

### 5.4.1 Mechanical or Mercury Contactor

Channels configured for use with contactors are capable of handling up to 3 amps, 24–120 volts AC only. THESE ARE CONTROL CIRCUITS FOR CONTACTORS ONLY; NO POWER FOR HEATING ELEMENTS SHOULD BE DIRECTLY ATTACHED TO THE OUTPUT CONTROL TERMINALS.

These circuits are optimized for reliable control of contactors, relays, and solenoids; they completely isolate the external voltage from the rest of the GB5 circuitry. Because the control voltage is AC, there is **no difference** between the upper and lower terminals. As long as they correspond to the same unit, they are symmetric. You should not think of one of them as “in” and the other as “out”.

These are passive switches and do not supply any power.  
These are passive switches and do not supply any power.  
These are passive switches and do not supply any power.

We cannot stress this too strongly: it is the cause of much confusion during installation. These circuits will control any AC voltage from 24 to 140 volts<sup>6</sup>. The voltage used will depend upon the type of coils in your contactor and is independent of anything related to the GB5. If you are using a contactor with less than 120 volt coils, you will probably need a step-down transformer to get the lower voltage. In new installations, a low voltage 24 or 36 volt control system may be preferable to a 120 volt system: such a system is safer and may more easily satisfy various electrical codes.

The control voltage, be it 24 or 120 volts AC, should be connected in series between the GB5 terminal and the appropriate contactor or solenoid. It is important to realize that the control voltage is not necessarily the same as that used to heat the oven. A 24 volt contactor may control a 240 volt oven, and usually does.

---

<sup>6</sup>European models can control up to 240 volts.



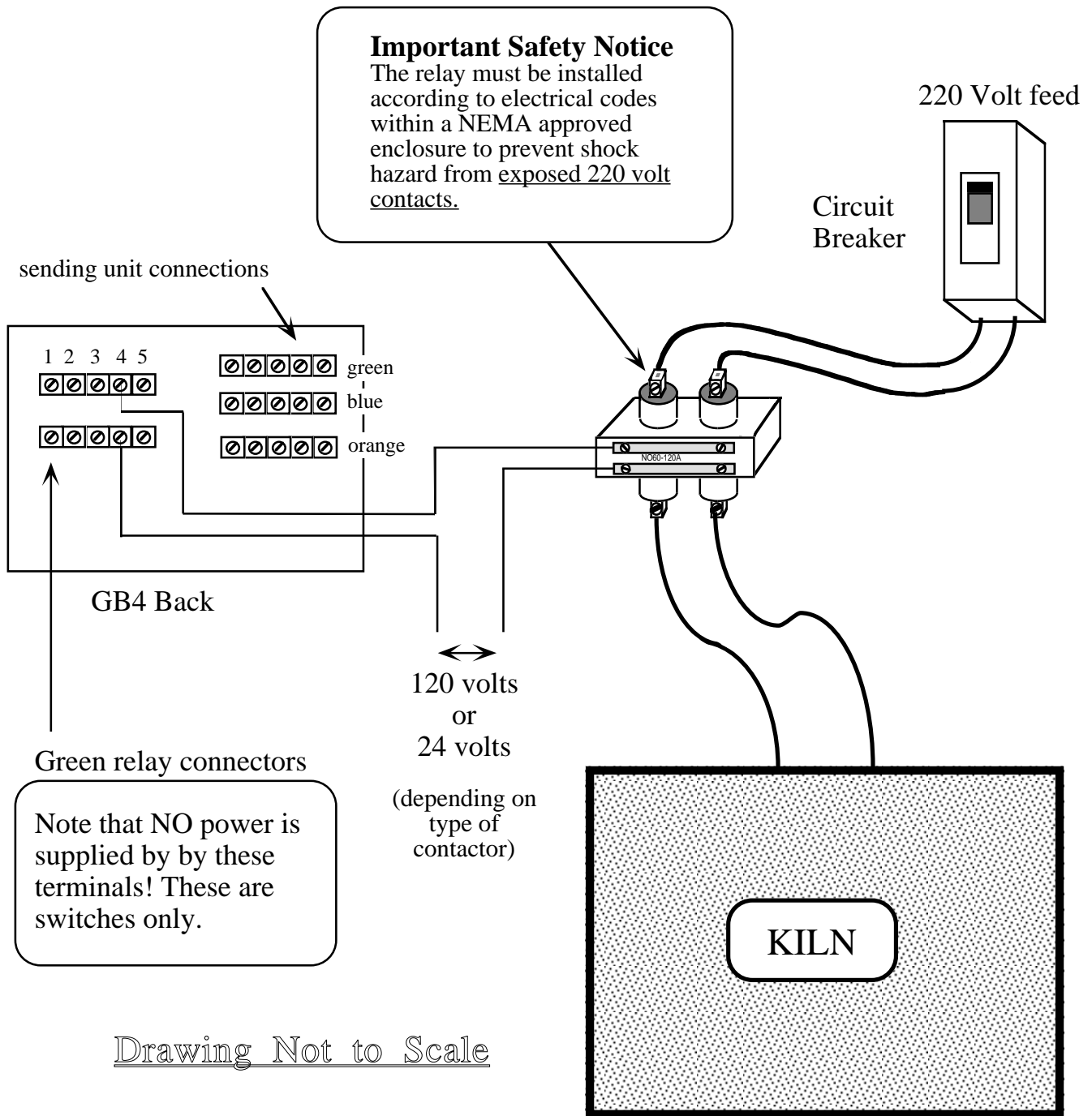

Figure 5.4: Contactor Connections

It is essential to have a switch or circuit breaker in the main heating element of each unit. This allows the independent shut-down of the unit in case of a malfunction or stuck contactor. Each output channel is fused internally. To check or replace these fuses, you must remove the front cover of the GB5.

**WARNING: TO PREVENT POSSIBLE DANGEROUS ELECTRIC SHOCK TO YOURSELF AND DAMAGE TO YOUR GB5, REMOVE THE COVER ONLY WHEN THE AC POWER IS TOTALLY DISCONNECTED FROM BOTH THE GB5 AND ALL CONTROL CIRCUITS.**

Note that even though fuses are provided, they do not guarantee total protection for the solid state output modules inside the GB5. In the event of excess current being drawn (from improper wiring, for example), these solid state devices may be damaged long before any fuse of a reasonable size could blow. Therefore, when installing your GB5, scrupulously review your wiring. Be certain there is no direct short across the output terminals before applying power to your contactor control circuits, as this will definitely blow out the output module. Also, be certain that you have connected the contactor wires to the correct terminals (on the left of the GB5, looking from the back, counting 1–5).

**WARNING: SERIOUS AND EXPENSIVE DAMAGE WILL OCCUR TO YOUR GB5 IF YOU APPLY 120 VOLTS, OR EVEN 24 VOLTS, TO THE THERMOCOUPLE INPUT TERMINALS OR TO THE WRONG OUTPUT TERMINALS. DO NOT BE CARELESS WHEN HOOKING UP THE CONTACTOR POWER. YOUR UNIT IS NOT GUARANTEED AGAINST DAMAGE DUE TO INCORRECT CONTACTOR WIRING.**

It is not possible to use an ordinary ohm meter or continuity checker to determine whether the outputs are on or off. This is because these test instruments are generally DC devices, and the output modules inside your GB5 will control only AC.

### 5.4.2 Solid-State Power Relay

With “pulse averaging” proportional control, also known as “pulse width modulation” or “PWM”, the oven is controlled by a solid-state power relay, which is pulsed on and off very rapidly. To the oven it seems to be partially on all the time. The percentage of “on” is determined by the number of pulses in a given second.

See figures 5.6 and 5.7 for installation diagrams.

Unlike a channel that controls a contactor, which needs external voltage, a channel that controls a solid-state relay provides 9–11 volts DC for the relay. Thus, these relays used should have a DC input. Commonly available types are either 3–15 or 3–60 volts

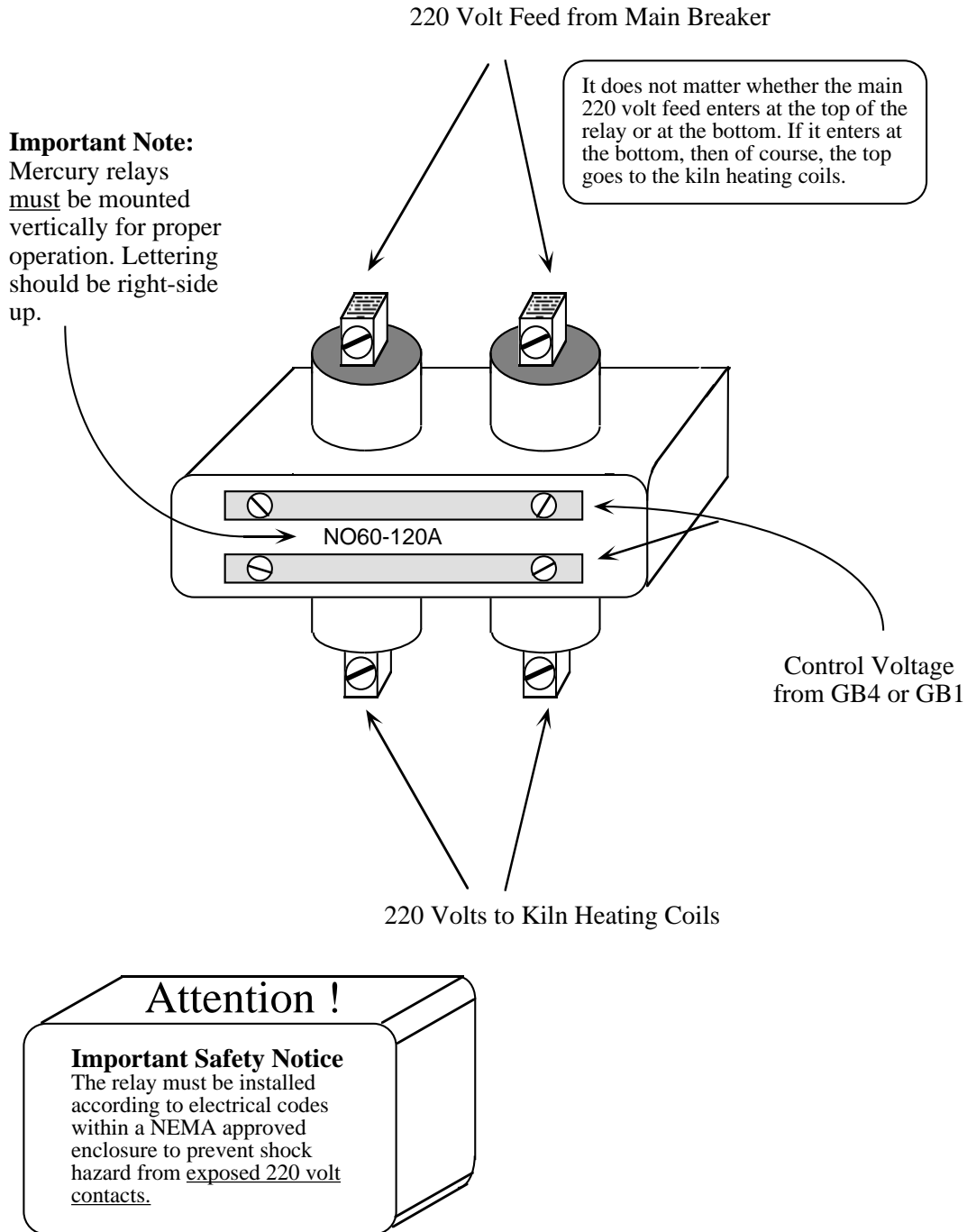
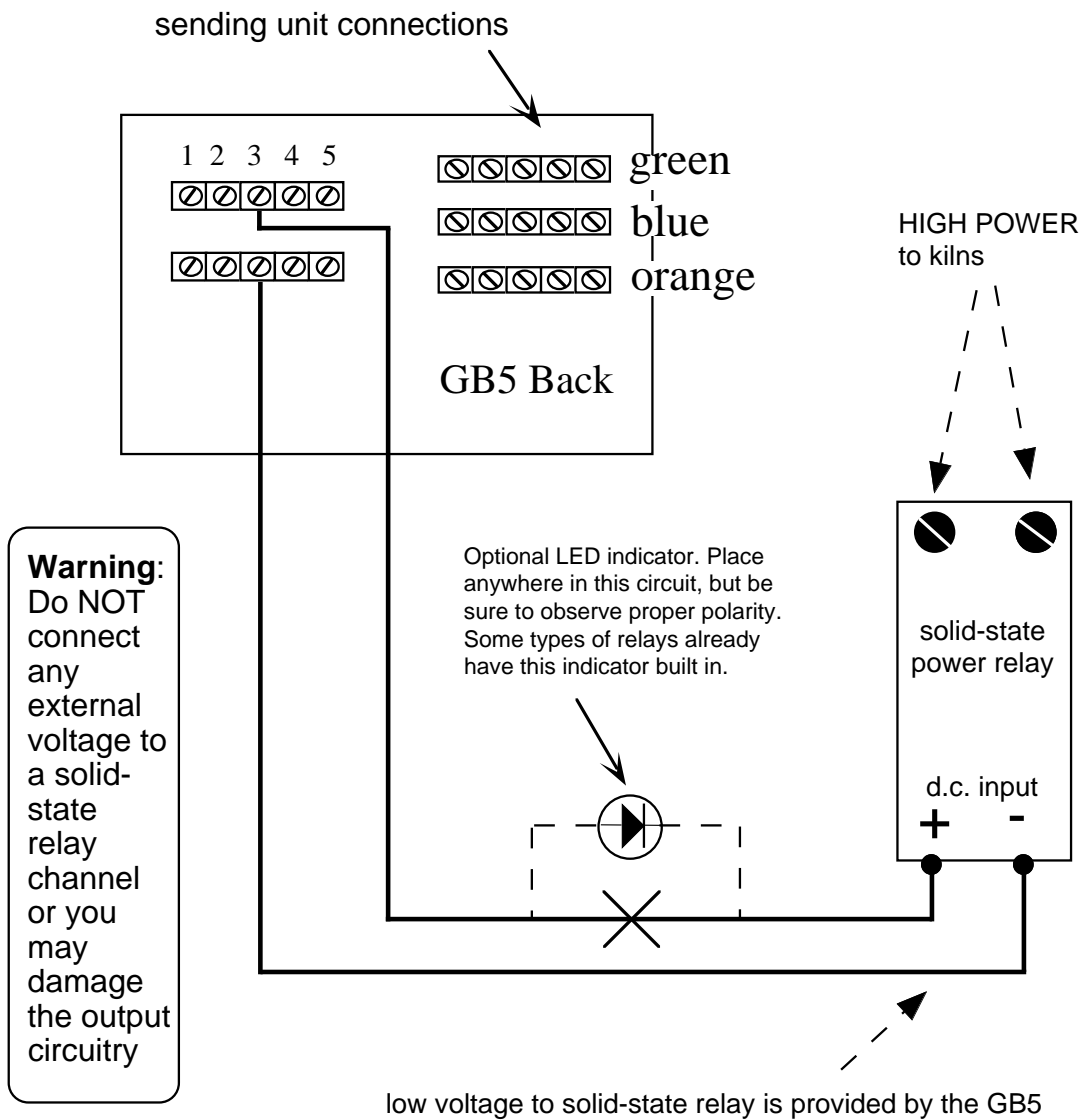

Figure 5.5: Typical Mercury Contactor Connections

GB5 connections of solid-state relay channel to a typical solid-state power relay



**Drawing not to scale**

Figure 5.6: Solid-State Power Relay Connection

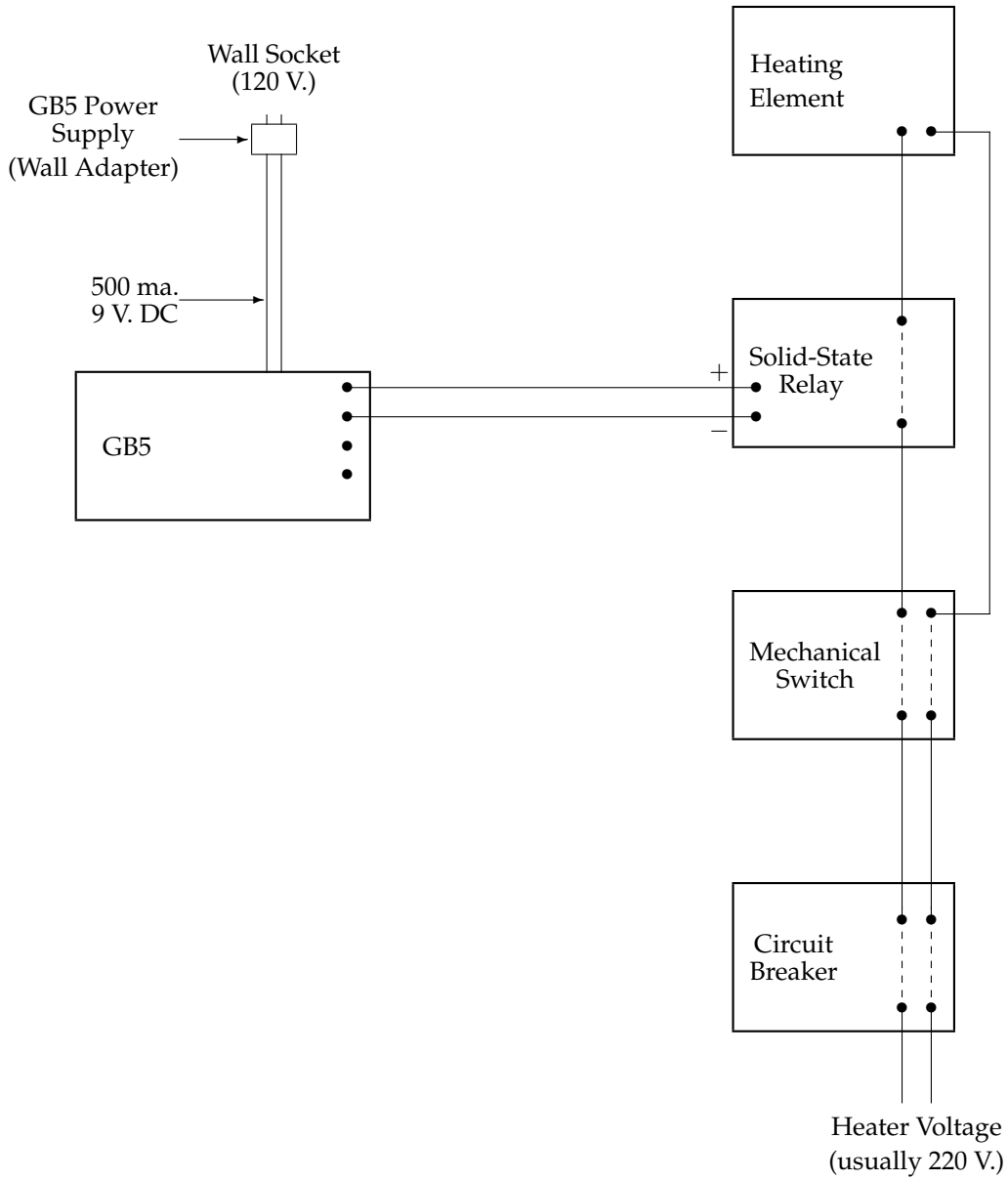

Figure 5.7: Recommended Solid-State Relay Installation

DC. As with all solid-state power relays, they must be provided with adequate heat-sinks or they will quickly fail. If in doubt, check with the supplier of your solid-state relay to be sure that it is properly installed.

It is also possible to use solid-state power relays without proportional control, *i.e.* as on/off control. In this case we still use the same solid-state relay connections.

Channels for solid-state relays differ from those for contactors in two very important ways.

1. External power is neither required nor allowed with solid-state relay channels. In particular, connecting 110–120 volt external power will instantly blow the fuse in the output circuit, and even then may cause damage to the GB5.
2. Connections for solid-state relays are polarized. It matters which goes where. The top terminal is positive and the bottom one is negative. If the polarities are reversed no damage will result, but the relays will not activate.

**Important safety consideration:** When using a mechanical or mercury relay to control a 220–240 volt line, it is normal practice to use a two-pole relay so that both sides of the line are switched. Therefore, when the relays are not actuated, there is no possibility of current flowing through the heating elements, so they are electrically safe to touch — though they may still be quite hot. With solid-state relays, this is **absolutely not true**. Solid-state relays are not open circuits when off; they are just high impedance circuits. Therefore, some current, possibly enough to shock a person, still flows. The only sure way to prevent shock is to mechanically disconnect the heating elements from the power source. One way to do this is to open the circuit breakers for the heating element circuit. If the breaker panel is not near the kiln, you can install a disconnect switch near the kiln.

**WARNING: ALWAYS COMPLETELY DISCONNECT THE HEATING ELEMENTS FROM ELECTRICAL POWER BEFORE TOUCHING THEM.**

And, of course, be sure they are cool.

### 5.4.3 4–20 Milliamp Current Loop

Some applications, such as a gas furnace using a Honeywell “Modutrol”<sup>7</sup> motor or similar device, require a 4–20 milliamp “current loop” for control. These devices are proportional, where the proportion is encoded as the amount of current flowing in a circuit. The amount of current in the circuit is determined or “conveyed” by the GB5. It is interpreted or “read” by the Modutrol motor, whose shaft angle adjusts itself according to the current. A “current loop” channel of the GB5 must be used in such an application.

---

<sup>7</sup>Modutrol is a brand name of Honeywell Corp.

GB5 connections of 4-20 ma furnace channel to a typical Honeywell Modutrol (tm) motor

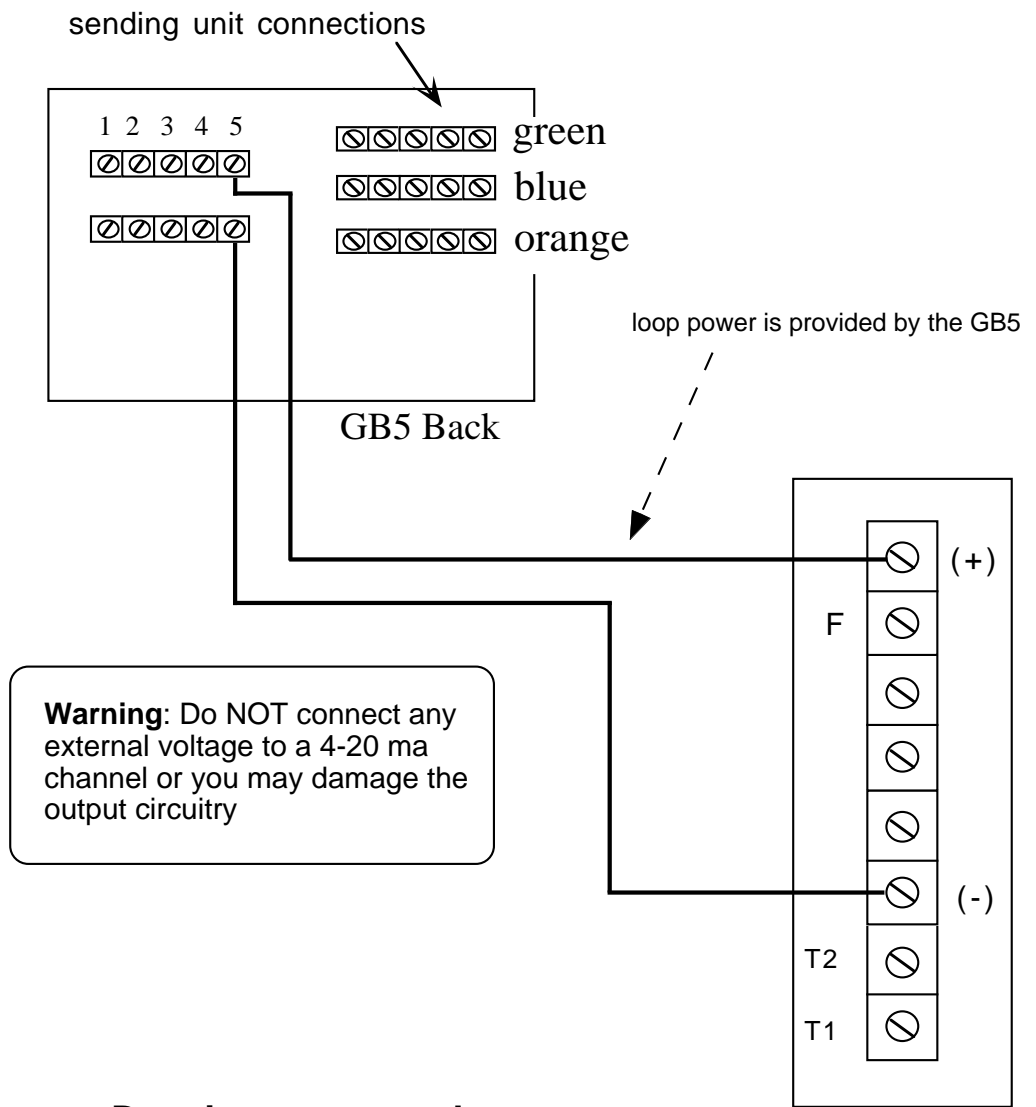

**Drawing not to scale**

Interior of Modutrol terminals - from top.  
Ref. fig. 5C in Modutrol manual.

Figure 5.8: Modutrol Series M72XX Connection

The connections are polarized. It matters which goes where. The top terminal is positive and the bottom one is negative. If the polarities are reversed no damage will result, but the external equipment will fail to actuate. The connections for a Honeywell series M72XX Modutrol motor are shown in figure 5.8. Connections to other brands of similar motors or phase-angle SCRs should be analogous. If the motor or SCR doesn't actuate, make sure that all polarities are as shown in one or the other diagram.

## 5.5 Powering Your GB5

The GB5 should be powered from a 120 volt AC grounded circuit (220–240 volt, 50 cycle available on special order). It is recommended that this circuit be used *only* for the GB5. If no independent circuit is available, do not operate motors or large equipment on this same circuit.

A proper ground is very important for the reliable operation of your GB5. Furthermore, it is needed to protect your GB5 from damage during fault conditions and voltage transients. Under no circumstances should the 3-pronged plug on the GB5 be removed or bypassed. If an extension cord must be used, it should be a 3-wire type (third wire is ground) with a 3-pronged plug.

The main power supply fuse is located inside of your GB5 near the transformer. It is rated at 1/2 amp even though your GB5 draws less than 1/8 amp. This is because line voltage transients can cause higher currents to flow temporarily. Our experience shows that it is quite unlikely that you will ever have to replace this fuse. After proper installation, the only reason that this fuse would blow (other than an internal component failure in the GB5) is a massive voltage transient on the power lines. In particular, problems with your contactors or with your thermocouples should not affect this fuse.

If it does need replacement, your GB5 will appear completely dark; it will not respond to any keys; and it will not control any kilns. To check or to replace the fuse, you will have to remove the cover of the GB5.

**WARNING: TO PREVENT POSSIBLE DANGEROUS ELECTRIC SHOCK TO YOURSELF AND DAMAGE TO YOUR GB5, REMOVE THE COVER ONLY WHEN THE AC POWER IS TOTALLY DISCONNECTED FROM BOTH THE GB5 AND ALL CONTROL CIRCUITS.**

## 5.6 Internal Protection

Considerable design effort has been devoted to protecting your GB5 against line voltage transients and transients at the Sending Unit connections. At the AC power input, transient spike protection is wired internally into the GB5. Any line voltage spike of more



than about 130 volts automatically is shorted to ground by the internal solid state circuitry. If these spikes are abnormally large, the power fuse may blow. If this fuse blows more than rarely, you have unacceptably noisy power. Contact Digity Company, Inc., for help in these circumstances.

There is also transient voltage spike protection both within each Sending Unit and where the signal lines enter the GB5. There are two fuses within each Sending Unit. You should not attempt to replace these fuses, because if they are blown, your Sending Unit and possibly your GB5 should be checked for additional damage. Furthermore, the fuses are soldered in and disguised so that you are unlikely to recognize them as fuses.

In spite of all this protection, contact between a thermocouple and a live heating element is likely to damage the Sending Unit as well as the GB5. The GB5 is not guaranteed against damage of this type. All thermocouples should be fastened securely to prevent contact with the heating elements.

Under no circumstances should you adjust the position of a thermocouple when the unit is heating. Not only do you risk damage to your equipment, you also risk a DANGEROUS ELECTRICAL SHOCK. Remember, the heating elements contain voltages as high as 240 volts (or even more), depending on exactly where they are touched. Thermocouples are made of metal. Metal conducts electricity. Even if your elements and thermocouples are encased in porcelain, care still must be used. Porcelain and other refractory materials become conductive at high temperatures and consequently do not give as much protection as you might assume.

## 5.7 DOs and DON'Ts

Like any tool you work with, the GB5 abides by a prescribed set of operating principles. Follow precisely the installation instructions detailed in this chapter. And, keep in mind the following “do”s and “don’t”s when installing your GB5.

- Do not run power for heating elements through GB5 relays.
- Do not misconnect or short together the wires to the Sending Units.
- Do remember that the GB5 controls contactors or solenoids by passive switches; it does not itself supply power.
- Do not run wires between the Sending Units and the GB5 in the same conduit or in close proximity to wires connected to heavy equipment or to power wires for relays or heating elements. This practice would introduce “noise” into the readings and may cause incorrect temperature readings.

- Do not reposition the thermocouple while the unit is running as it may touch a live heating element and put 120 (or 240 or even higher) volts through the thermocouple input. This will cause expensive damage and possibly dangerous shock.
- Do not remove the front cover of the GB5 until all AC power is removed from both the GB5 and all control circuits. This will prevent possible shock to you and damage to your GB5.
- Do ground your GB5 properly.
- Do not remove or bypass the 3-pronged plug on your GB5.

## 5.8 Additional Help

If you have any questions about installing your GB5 after reading this chapter, please call Digitry Company, Inc., so that we can provide you with the information you need.

# Chapter 6

## Reference

### 6.1 GB5 Specifications

The GB5 Programmable Temperature Controller, basic model, is equipped with two Sending Units for use with Type K thermocouples. Additional Sending Units, Type S capabilities, key lock security and customized hardware and software are optional.

**Power Requirements:** 10 watts at 110–120 volts AC, 60 cycle, grounded outlet (220–240 volts, 50 cycle available).

**Temperature Measurement Range:** 5 channels, 32° to 2372°F (0° to 1300°C) with automatic cold junction compensation for Type K; 5° to 3200°F (10° to 1760°C) for Type S.

**Resolution:** 1 part in 4100.

**Repeatability:** 1°F.

**Timing:** crystal controlled.

**Common Mode Rejection Ratio:** at 60 Hz (at thermocouple) for Type K, 126 dB minimum; for Type S, 148 dB minimum.

**Output:** 5 channels, ON/OFF control via solid state relays with zero crossing detection; 1.5 amps at 24–140 volts AC, fused internally. Options: (a) 24–280 volts AC, (b) 3–60 volts DC, (c) 3, 4 or 5 amps.

**Programming:** 9 programs; 15 set-points per program; maximum of 543 hours in one minute increments for each program.

**Dimensions (H×W×D):** 9" × 12 $\frac{11}{16}$ " × 6 $\frac{1}{8}$ "

**Shipping Weight:** 7 lbs. (3.18 kg.)

**Operator Interface:**  $\frac{1}{2}$ " , 7-segment, red LED; 16-position sealed keyboard (dust and moisture resistant).

## 6.2 Accuracy

While the absolute accuracy of the GB5 is limited to about 1%, the resolution always is approximately 0.5°F. This yields more than 0.025% of full scale reading. With a given GB5 and fixed thermocouple location, your temperature profiles are repeatable to an extremely high degree of accuracy. More variation will be introduced by the way you load your unit than by the accuracy of your readings.

To help ensure this repeatability, all Type K Sending Units are equipped with automatic cold junction compensation to account for variations in room temperature. Such variations ordinarily would appear as an error in the temperature reading. This is because a thermocouple measures the difference in temperature between the hot end and the point where the Sending Unit is attached, *not* the absolute temperature. With cold junction compensation, these errors are eliminated.

It is important to realize that because of the resolution of the GB5 temperature measurement, you will note swings in the temperature of your unit that would go unnoticed with a standard, meter type pyrometer. These swings are to be expected. They were always there, you just could not see them. You should notice that the more material you place in your unit, the less severe the swings.

## 6.3 Sales and Service

The main offices of Digitry Company, Inc., are located at:

188 State Street, Suite 21  
Portland, ME 04101  
USA  
Phone +1-207-774-0300  
Email [info@digitry.com](mailto:info@digitry.com)  
Internet [www.digitry.com](http://www.digitry.com)

Write or call for all sales, service, or technical information.

## 6.4 Loaner Program

If your GB5 should malfunction after the warranty has expired, you can return the GB5 to Digitry for repair.

Realizing that the GB5 will become an indispensable part of your production facility, Digitry will, upon request, immediately send a GB5 "loaner" for the duration of the repair. Please call the Maine office for the current cost of the loaner and the deposit amount. There is a daily surcharge if the loaner is kept for more than 3 working days after you receive your repaired GB5.

## 6.5 Warranty Information

DIGITRY COMPANY, INC., ("SELLER") WARRANTS THAT THE PROGRAMMABLE TEMPERATURE CONTROLLER ("PRODUCT") SOLD TO PURCHASER SHALL BE OF STANDARD QUALITY OF SELLER. SELLER'S OBLIGATION AND LIABILITY UNDER THIS WARRANTY IS EXPRESSLY LIMITED TO REPAIRING OR REPLACING, AT SELLER'S OPTION, A PRODUCT NOT OF SELLER'S STANDARD QUALITY FOR A PERIOD OF NINETY (90) DAYS FROM THE DATE OF DELIVERY. SELLER MAKES NO OTHER WARRANTY, EXPRESS OR IMPLIED, AND MAKES NO WARRANTY OF MERCHANTABILITY OR OF FITNESS FOR ANY PARTICULAR PURPOSE. SELLER'S OBLIGATION UNDER THIS WARRANTY SHALL NOT INCLUDE ANY TRANSPORTATION CHARGES OR COSTS OF INSTALLATION OR ANY LIABILITY FOR DIRECT, INDIRECT OR CONSEQUENTIAL DAMAGES, DELAY OR LOSS OF PROFITS, EVEN IF SELLER HAS BEEN INFORMED BY PURCHASER OF THE POSSIBILITY OF SUCH DAMAGES.

IF REQUESTED BY SELLER, A PRODUCT ON WHICH A WARRANTY CLAIM IS MADE SHALL BE RETURNED TRANSPORTATION PREPAID TO SELLER'S PRINCIPAL PLACE OF BUSINESS. ANY IMPROPER USE, OPERATION, SUBSTITUTION OF PARTS, OR ALTERATION OR REPAIR BY OTHERS IN SUCH A MANNER AS IN SELLER'S JUDGMENT AFFECTS A PRODUCT MATERIALLY AND ADVERSELY SHALL VOID THIS WARRANTY. NO EMPLOYEE OR REPRESENTATIVE OF SELLER IS AUTHORIZED TO CHANGE THIS WARRANTY IN ANY WAY OR TO GRANT ANY OTHER WARRANTY.



# Chapter 7

## Glossary

### **Auto-Hold**

Automatic function that halts the unit timer if the actual temperature varies too far from its programmed temperature.

### **Channel**

All the components, both hardware and software, that refer to a given unit.

### **Cold Junction Compensation**

Mechanism incorporated into Sending Unit that adjusts for variations in room temperature.

### **Confirmation Sequence**

A feature of the GB5 that requires you to enter a specific sequence of keys to prevent accidental starting, erasing, or resetting of programs.

### **Contactors**

Another name for a large relay (see below).

### **Current Loop**

A way of encoding a power level as a small current running through a circuit. Usually 4 milliamps means no power, 20 milliamps means full power, and current levels between 4 and 20 milliamps represent the corresponding intermediate power levels. Many proportional control devices, such as servo-motors and SCRs, are controlled in this way. GB5s are available with one or more channels set up to control a current loop.

### **Heat-Sink**

A large piece of metal, sometimes with fins, to absorb and dissipate heat generated by a solid-state power relay.

**Hold**

Function that stops the unit timer and maintains the programmed temperature for an indefinite period of time (also known as an indeterminate “soak”).

**Idle**

Condition in which control power to a unit and the unit timer are off and the GB5 is ready to start at the beginning of a profile.

**Key Lock**

Optional feature that prevents accidental or unauthorized program changes.

**Looping**

Command that triggers the indefinite repetition of a temperature profile.

**Memory Back-up**

Safety device to ensure program retention in the event of power failure.

**Mercury Displacement Relay**

A special type of relay that uses liquid mercury to make electrical contact. This type of relay is quieter, more reliable, and more expensive than ordinary mechanical relays and is recommended for applications where currents in excess of 30 amps must be controlled.

**Modutrol Motor**

A type of servo-motor made by Honeywell which is used to control gas valves *etc.* The motor adjust its shaft angle according to a electrical signal, usually a current between 4 and 20 milliamps.

**Monitor Mode**

Operating mode used to display current time and temperature set-points for a given unit. GB5 must be in this mode to start or stop a unit.

**On/Off Control**

A method of controlling an oven where the power is either full-on or full-off, depending on whether the oven temperature is below the set-point or above the set-point. This is the simplest and least costly form of control to implement and troubleshoot. It is particularly well suited for use with mechanical or mercury relays. Most GB5s use this method.

**Output Module**

Special electronic (“solid-state”) relay used within the GB5 by which it controls your contactors.



**Oven**

An oven, kiln, lehr or furnace.

**Phase-Angle Triggered**

A method of getting intermediate power levels from an SCR or similar device by turning off the power for a certain part of each cycle of AC electricity. While this method can theoretically give a very fine resolution of power levels, it is quite undesirable because it generates a large amount of electromagnetic interference. Phase-angle triggering “chops” up the individual cycles, whereas PWM uses a percentage of complete cycles to achieve the same result with almost no electromagnetic interference. Before the advent of digital electronics, phase-angle triggering was the only way to get intermediate power levels.

**PID**

Stands for “Proportional, Integral, Derivative”. This is sometimes used informally as a general expression to characterize proportional control.

**Power Sharing**

A scheme for controlling units that permits only one of a specified group to heat at any one time, thus limiting the maximum power needed. Available as a GB5 option.

**Program Mode**

Operating mode that permits entering, changing or examining GB5 temperature profiles.

**Proportional Control**

A method of controlling an oven in which the power level is adjusted to an intermediate value. GB5s are available with one or more channels set up to use Proportional Control.

**PWM**

Stands for “Pulse Width Modulation”. This is a method an on/off output can be made to simulate intermediate power levels. For example, if the power is on half of every second, this is an average power level of 50 %. If it’s on 750 milliseconds out of every second, it represents three-quarters power. Although most commonly used with solid-state relays, this method can also be used with mechanical and mercury relays if the cycle time is long enough. GB5s are available with one or more channels set up to use either type of PWM.

**Pyrometer**

Instrument for measuring high temperatures, commonly (but incorrectly) used to refer to a thermocouple probe.

**Ramping**

An increase or decrease in temperature over time.

**Relay**

An electromagnetically actuated switch controlled by a small amount of power that, in turn, controls a larger amount of power. Large relays are also referred to as “contactors.”

**Run**

State in which the unit timer is activated and the unit follows its programmed operations.

**Scan Function**

Feature that automatically cycles through each unit, displaying time and temperature for a few seconds before going to the next one.

**SCR**

Stands for “Silicon Controlled Rectifier”. This is an earlier version of the solid-state power relay. It is not so integrated as a modern solid-state relay, but some of these devices can handle awesome amounts of power. They are frequently phase-angle triggered and controlled by means of a 4-20 milliamp current loop.

**Sending Unit**

Small aluminum box that contains a thermocouple amplifier to raise the small (millivolt) signal from the thermocouple to higher level, more appropriate for sending back to the GB5. It also provides the cold junction compensation.

**Set-Point**

The target temperature of the oven at any given instant. During a soak, the set-point is the soak temperature. When your GB5 is ramping up or down, the set-point can change as often as every minute. The GB5 automatically calculates the set-point based on elapsed time and the profile you have entered. This term is also used for the temperatures and times you punch in to define a program.

**Single Phase Power**

The normal type of electrical service. The power is delivered by means of two wires. The voltage may be 110–120 or 220–240. For 110–120 volt single phase power, a single pole relay is sufficient. For 220–240 volt single phase power a two pole relay is used.

**Skip-step**

Function that instructs the program to jump to the following programmed step.

**Slope**

The pitch, or rate of increase or decrease in temperature, determined by time and temperature set-points.

**Soak**

Function that holds a specific temperature setting for a designated period of time.

**Solid-State Relay**

A type of relay constructed entirely of semi-conducting materials. It has no moving parts to wear out, but is nevertheless subject to electrical and thermal failure. Large Solid-State Relays, called Power Relays, can control the main heating power for an oven. Because they have no moving parts they can be turned on and off very quickly. This makes them ideal for use with PWM proportional controllers. Solid-State Relays inherently waste a small amount of power when they are on, and require a heat-sink to remove the heat this generates. A Power Solid-State Relay which is not properly fitted with a heat-sink will destroy itself from overheating.

**Step**

A single set of time and temperature instructions to be executed in a program, corresponding to a single ramp up, ramp down, soak or hold.

**Thermocouple**

Temperature sensing device placed inside an oven or kiln. The composition of the thermocouple determines its type. Type K is chromel-alumel; Type S, platinum rhodium.

**Thermocouple extension wire**

Wire that has the same characteristics as thermocouple wire at low temperatures but different ones at higher temperatures. It is used for extensions, especially of Type S thermocouple leads, because it is cheaper than thermocouple wire.

**Three-Phase power**

A type of electrical service where the power is delivered by means of 3 separate wires instead of just 2. The voltage between any two wires is usually 208 volts AC. Three-phase power is usually found only in industrial or ex-industrial environments. To control three-phase power you usually use a 3-pole relay.

**Unit**

An oven, kiln, lehr, or furnace.

**Voltage transient**

An electrical disturbance of very short duration, typically caused by lightning or by heavy electrical equipment.

**Zero-Crossing Relay**

Many AC solid-state relays have built in circuitry to detect when the load voltage is near zero, and they do not switch the load on or off until this occurs. This means that individual cycles of AC power are not “chopped” which in turn limits the generation of electromagnetic interference. The zero voltage switching also limits inductive “kickback” from relay coils, making for much more reliable operation of electronic equipment, including the GB5 itself.

**Zone Control**

A method of individually controlling sections of a large unit, while keeping them synchronized, for the purpose of maintaining a more uniform temperature distribution. Each section is referred to as a “zone” and corresponds to one channel of a GB5.

# Chapter 8

## Troubleshooting

Symptom	Likely Cause	Suggested Actions
GB5 appears dead	No Power to GB5	<ol style="list-style-type: none"><li>1. Check that GB5 is plugged in to a live circuit.</li><li>2. Check internal fuse, lower right-hand side of back circuit board.</li></ol>
One channel reads 32°F	Defective sending unit, wires to sending unit broken or disconnected	<ol style="list-style-type: none"><li>1. Try exchanging the sending unit with another that is known to work.</li><li>2. Try using new wire to connect the sending unit to the GB5.</li></ol> Send defective sending unit to Digitry.
All channels read 32°F	Power for all sending units has failed	Send GB5 and sending units to Digitry for repair.
All channels read approximately 33–38°F	Short circuit between blue and orange wires or defective sending unit.	Remove all sending units. Add back one at a time until all have been tested. If one or more appear bad, send them to Digitry for repair. If all appear bad, send GB5 and sending units to Digitry for repair.

Symptom	Likely Cause	Suggested Actions
Sending unit buzzes	Burnt out or defective thermocouple, defective sending unit, or short circuit between green and orange wires	<ol style="list-style-type: none"> <li>1. Try exchanging sending unit with another that is known to work.</li> <li>2. Try replacing thermocouple with one known to be good.</li> <li>3. Try replacing thermocouple with short piece of wire. GB5 should display approximate room temperature, and sending unit should stop buzzing. If this happens, your thermocouple is bad; replace it with a good one (don't forget to remove the short piece of wire). If it doesn't, send defective sending unit to Digistry for repair.</li> <li>4. Disconnect both the GB5 and the sending unit from their wires. Then attach the GB5 to the sending with short lengths of wire, where you can see that they don't short out. If this stops the buzzing, the problem is in your wiring.</li> </ol>
Erratic temperature readings for one or more units	Defective multiplexor chip	Contact Digistry for replacement chip. Most people can replace this themselves.
One or more units do not heat	Room temperature too cold	Heat thermocouple above 50°F (hold in hand or apply direct heat).
One unit does not heat	Defective contactor or internal GB5 fuse has blown	Try actuating the contactor manually (carefully short out connectors at back of GB5—WARNING: electrical shock hazard). If unit begins to heat, check internal micro-fuse for that channel (if necessary, swap fuse with working channel). If fuse is bad, obtain replacements from Digistry; they are hard to find locally. If fuse is OK, return GB5 to Digistry for repair. If unit does not heat, check wiring or replace contactor.

# Programming Forms

The following pages are blank Digitry programming forms (*cf.* Figure 3.2, page 23).







Copy Freely &  
Use Genuine Digitry Controllers

## Digitry GB5 Programming Form

Oven # \_\_\_\_\_

Date \_\_\_\_\_

Use \_\_\_\_\_

Author \_\_\_\_\_

	Step 1	Step 2	Step 3	Step 4	Step 5
Temp					
Time					

	Step 6	Step 7	Step 8	Step 9	Step A
Temp					
Time					

	Step B	Step C	Step D	Step E	Step F
Temp					
Time					

Notes:





Copy Freely &  
Use Genuine Digitry Controllers

## Digitry GB5 Programming Form

Oven # \_\_\_\_\_

Date \_\_\_\_\_

Use \_\_\_\_\_

Author \_\_\_\_\_

	Step 1	Step 2	Step 3	Step 4	Step 5
Temp					
Time					

	Step 6	Step 7	Step 8	Step 9	Step A
Temp					
Time					

	Step B	Step C	Step D	Step E	Step F
Temp					
Time					

Notes: